

# FIJN FAAM FANTASTISCH

## OMGEVING

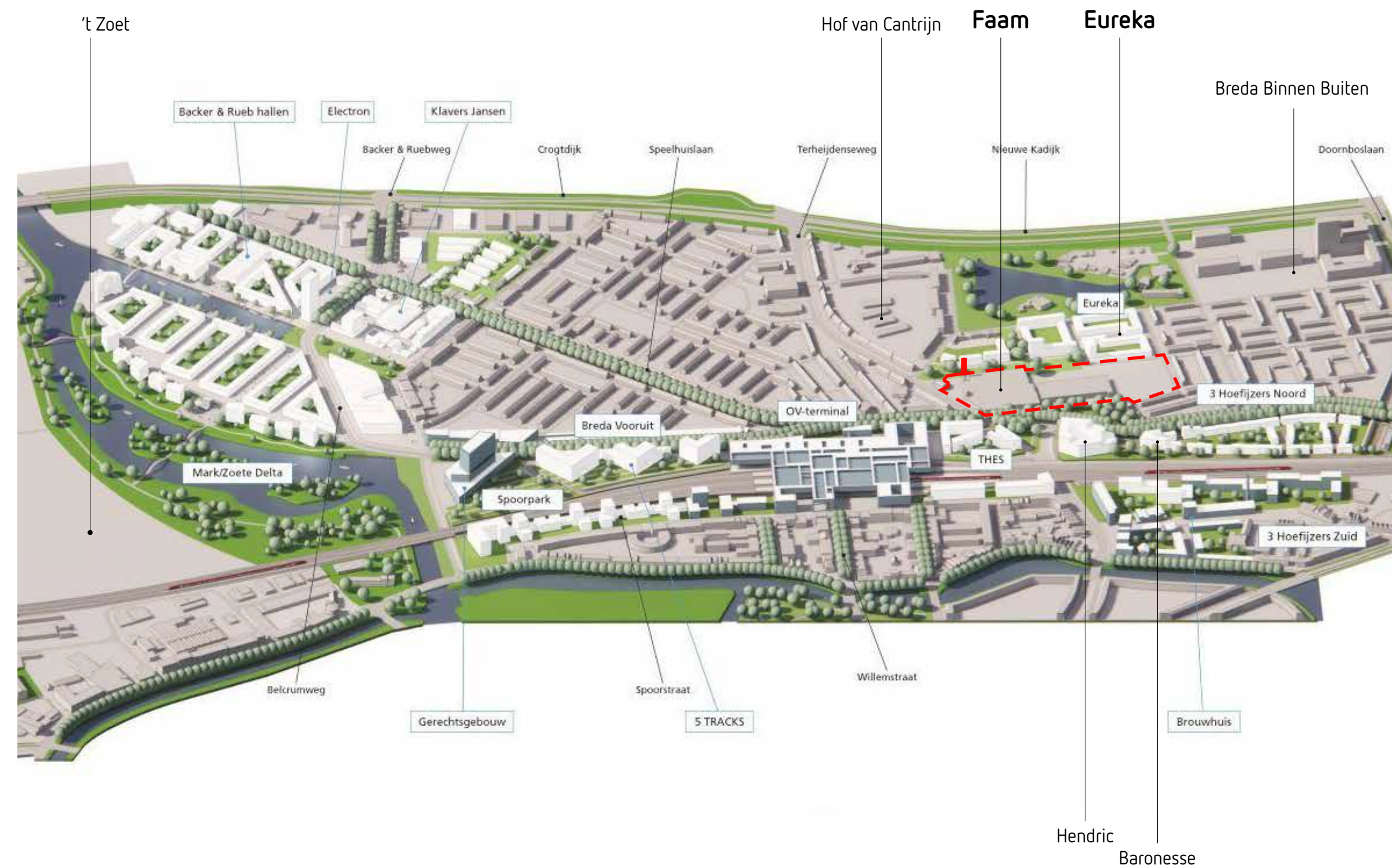

Faam luchtfoto



Schema : Ontwikkelingen CROSSMARK Breda



Appartementengebouwen Breda Binnen Buiten



Typische bebouwing Linie



Impressie Eureka vogelvlucht



Faam-locatie met ontwikkelplannen omgeving



Ontwikkeling Baronesse



Ontwikkeling Hendric



Faam reclame posters



Faam interieur fabriekshal



Typische bebouwing Belcrum



OV-terminal



Ontwikkeling Thes



# FIJN FAAM FANTASTISCH

## STEDENBOUW

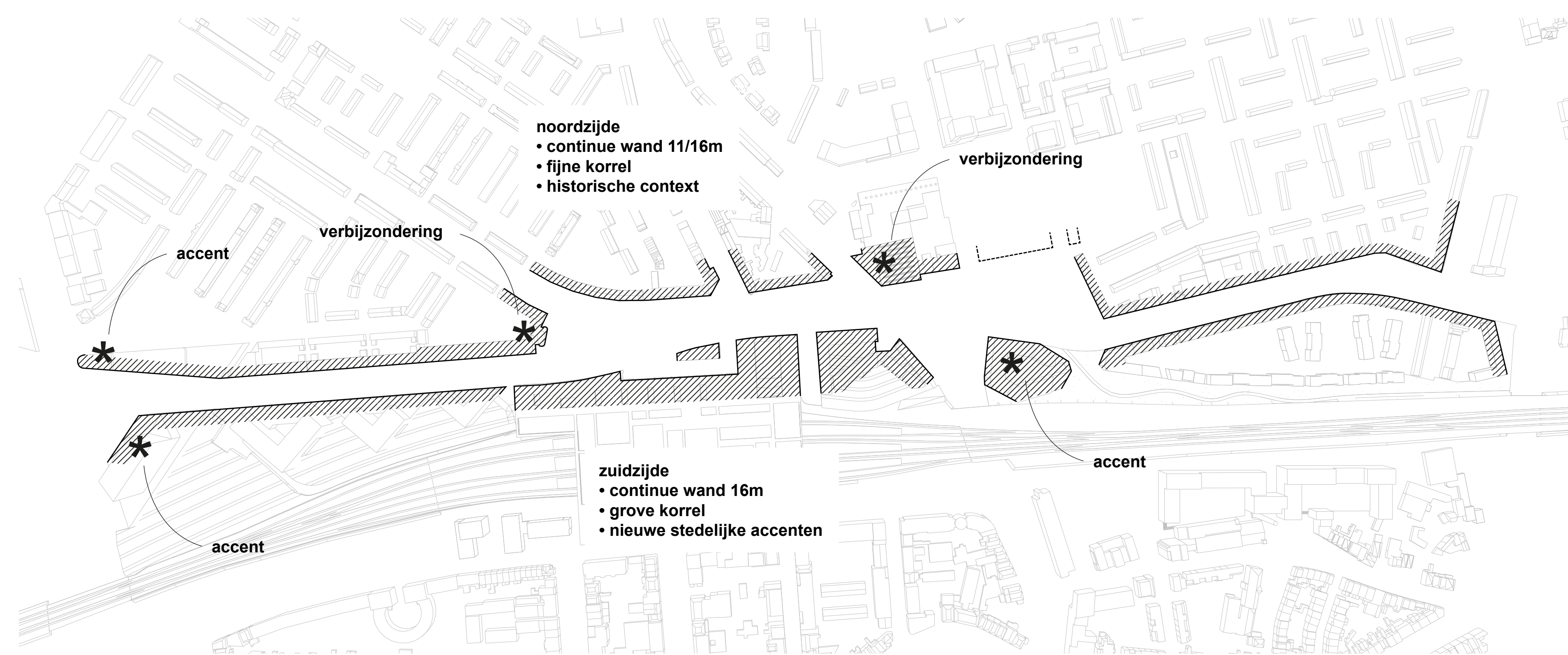
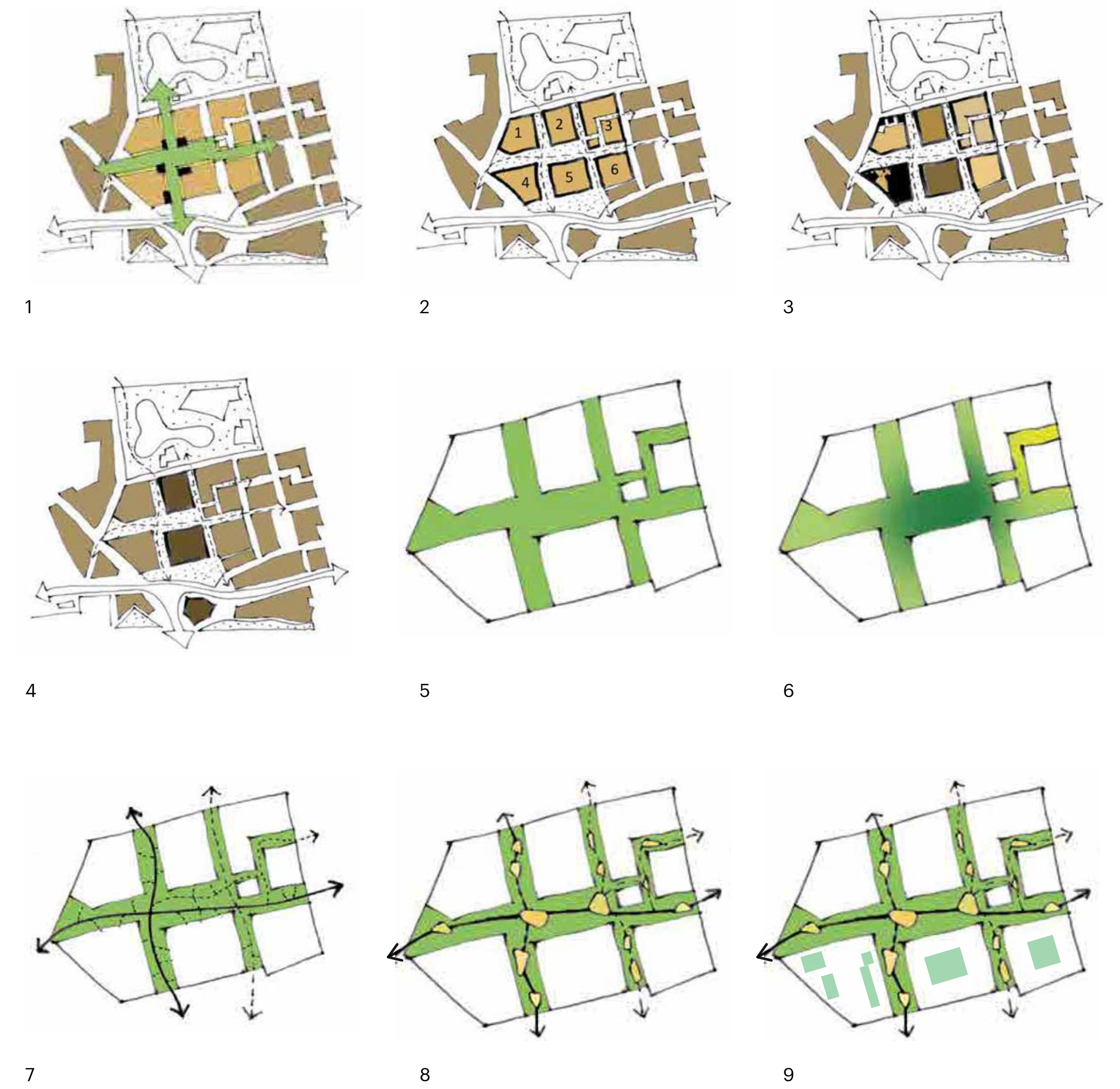

Stedenbouwkundige context Stationslaan ('Faam atelier' document, 11.04.2022)

- 1 Centrale as en plek
- 2 Zes bouwvelden door verbinden van routes
- 3 Elk bouwveld heeft een eigen expressie
- 4 Hoogstedelijke clusters in de centrale as
- 5 Maximaal groen tussen de bouwvelden
- 6 Groene ruimte 'kleurt mee' met omgeving
- 7 Een fijnmazig netwerk van paden
- 8 Het verbinden van plekken en knopen
- 9 Ontstaan nieuwe plekken vanuit het erfgoed

Totaalvisie Eureka-Faam ('Faam atelier' document, 11.04.2022)

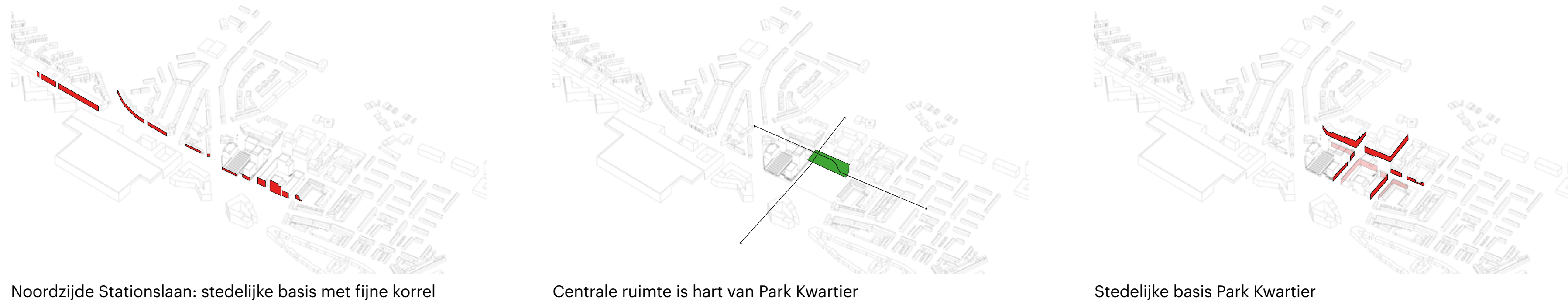

Visiekaart : Hoogbouwstructuren - Gemeente Breda

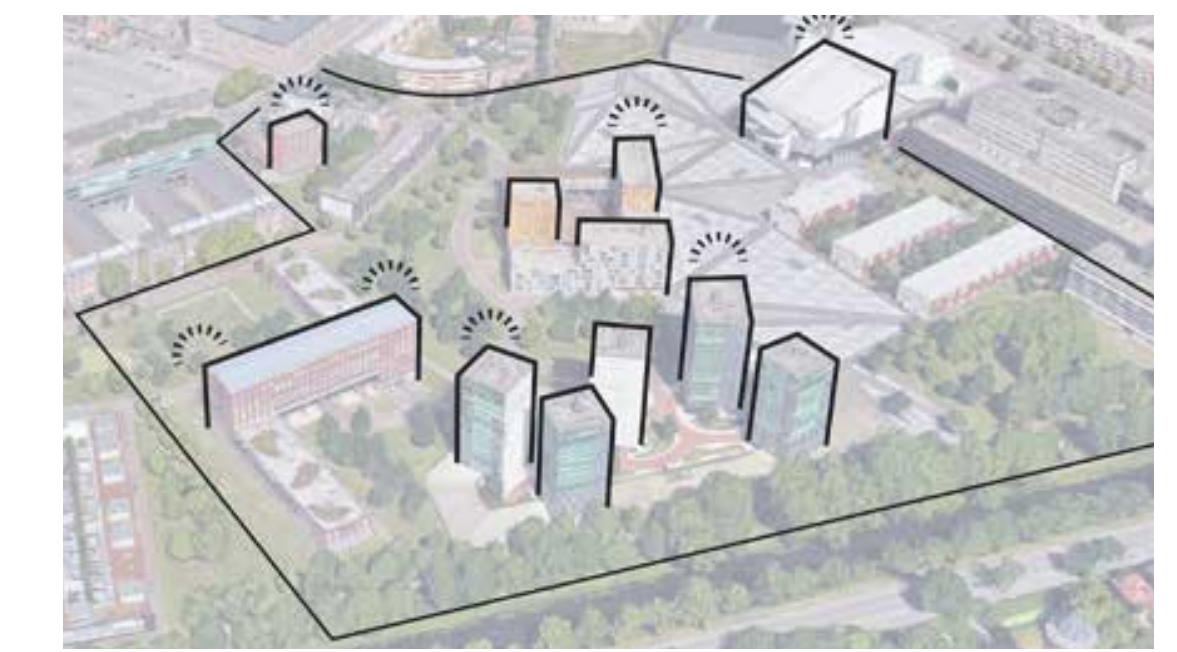

Schema : Hoogbouwstructuur - Gemeente Breda



# FIJN FAAM FANTASTISCH

## ERFGOED ALS INSPIRATIE

### Energie

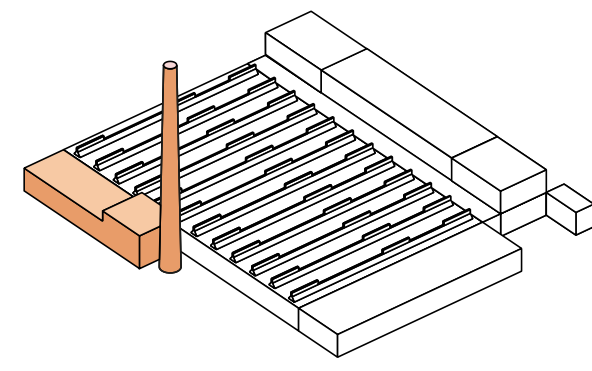

1915 - 1920  
Bouw van het energiegebouw met de metselwerk schoorsteen

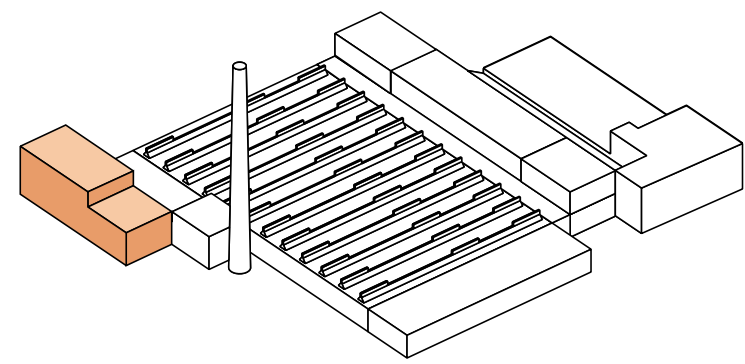

1935  
Bouw machinehal tegen de westzijde van de fabriekshal

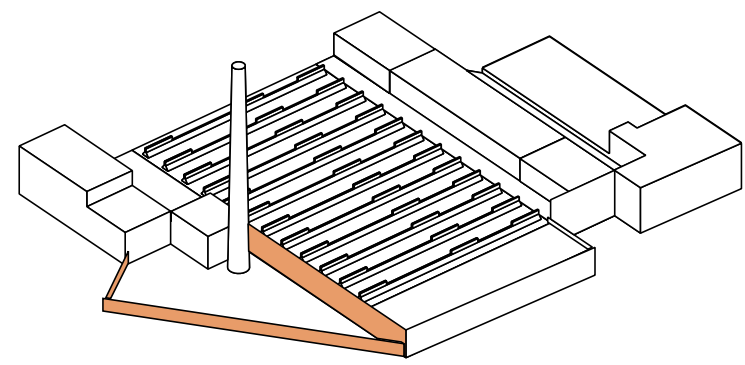

1941  
Bouw van de scherm- en schansmuur

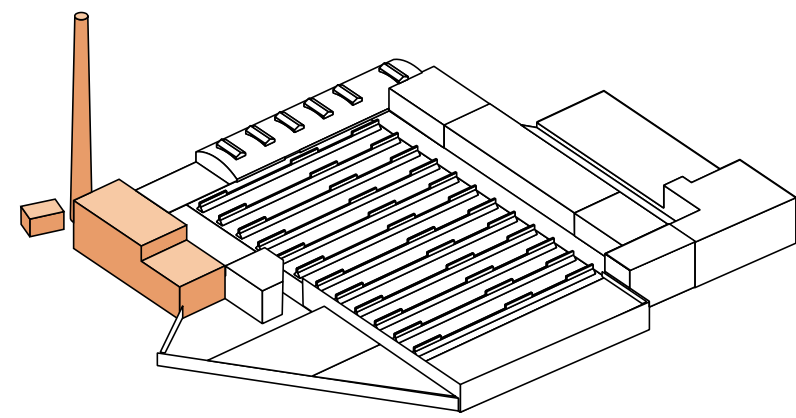

1960  
Van machinehal naar ketelhuis, schoorsteen vervangen.



Plaatsen van ketel, omstreeks 1960

### Productie

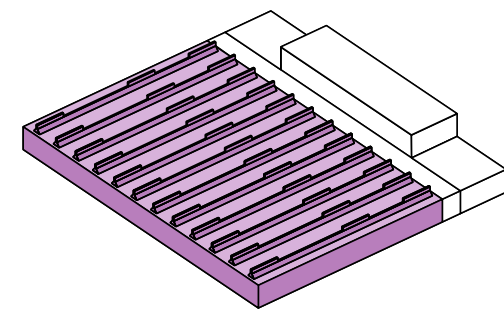

1912  
Bouw van de fabriekshal

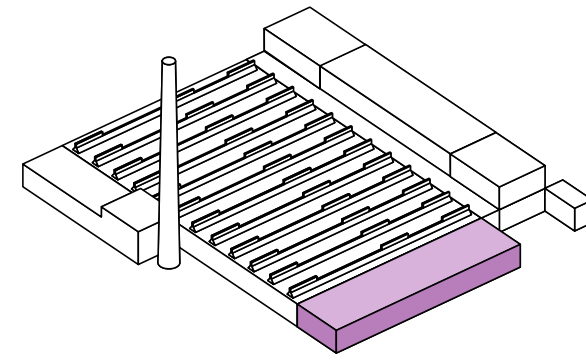

1915 - 1920  
Uitbreiding van de fabriekshal

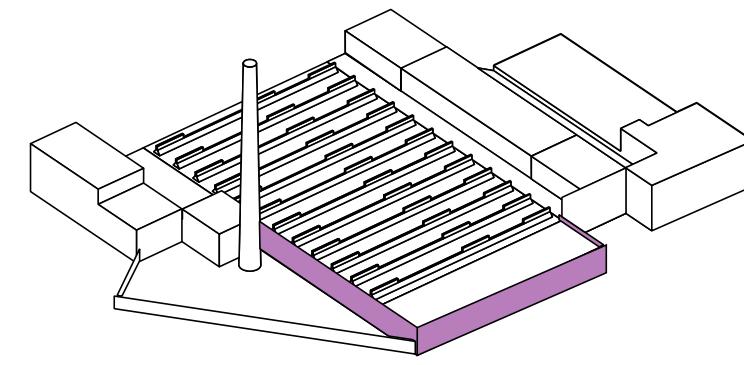

1941  
Realisatie van nieuwe (scherm) gevels

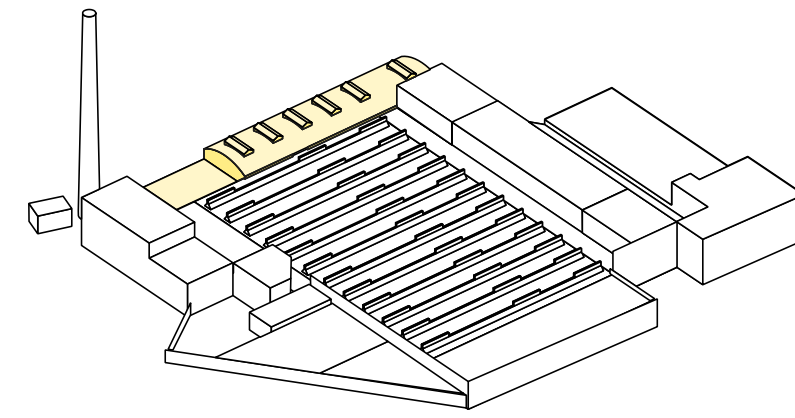

1954  
Bouw van een fabriekshal met Fuséedak



Faamcomplex, jaren 50

### Kantoor

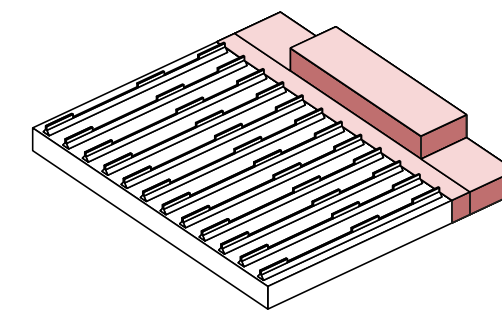

1912  
Bouw van het kantoor

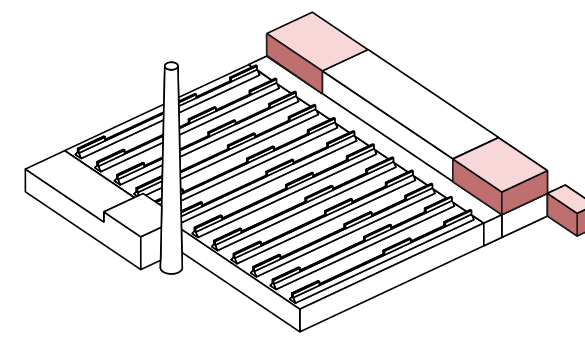

1915 - 1920  
Uitbreiding kantoorgebouw/verpakkingsafdeling en expeditie

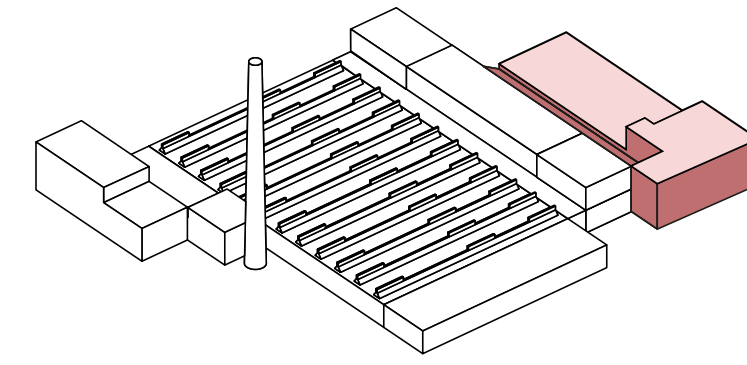

1930  
Bouw van een nieuw kantoorgebouw

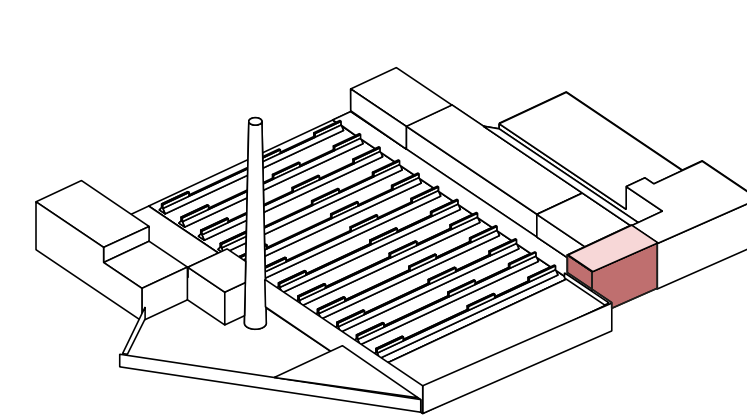

1949  
Uitbreiding van het magazijn en de expeditie



Kantoorgevel, jaren 40

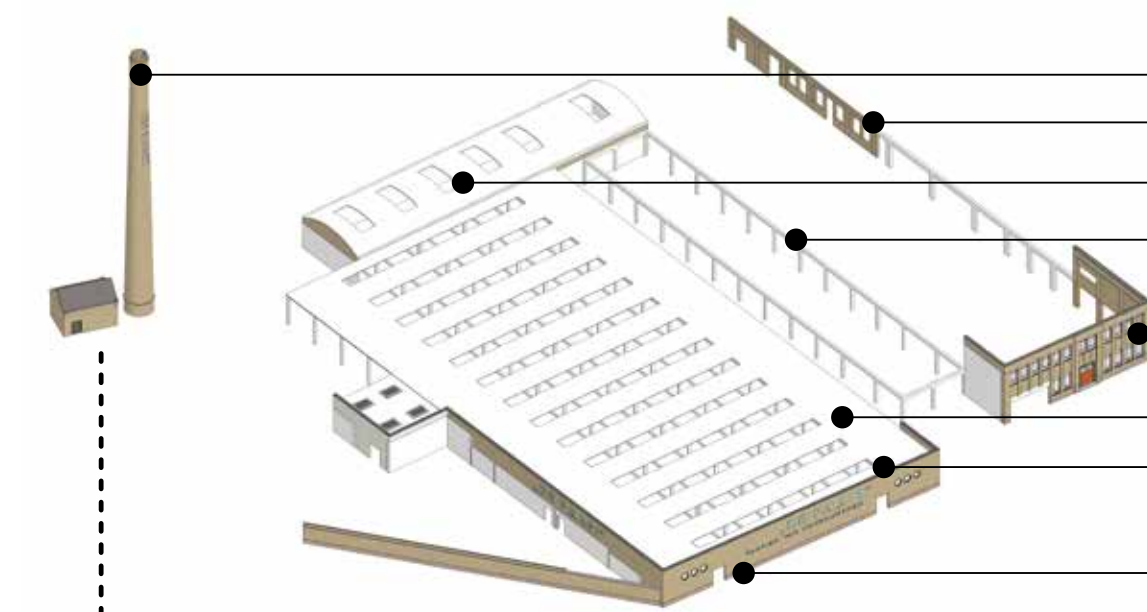

Te behouden :  
Elementen met hoge monumentale waarde

- Schoorsteen 1960
- Uitbreiding 1955 - 1980 (gevel)
- Fuséehal 1954
- Kantoor 1912 (constructie)
- Kantoor 1930 (gevel)
- Fabriekshal 1912
- Fabriekshal uitbreiding 1915
- Schermgevel 1941

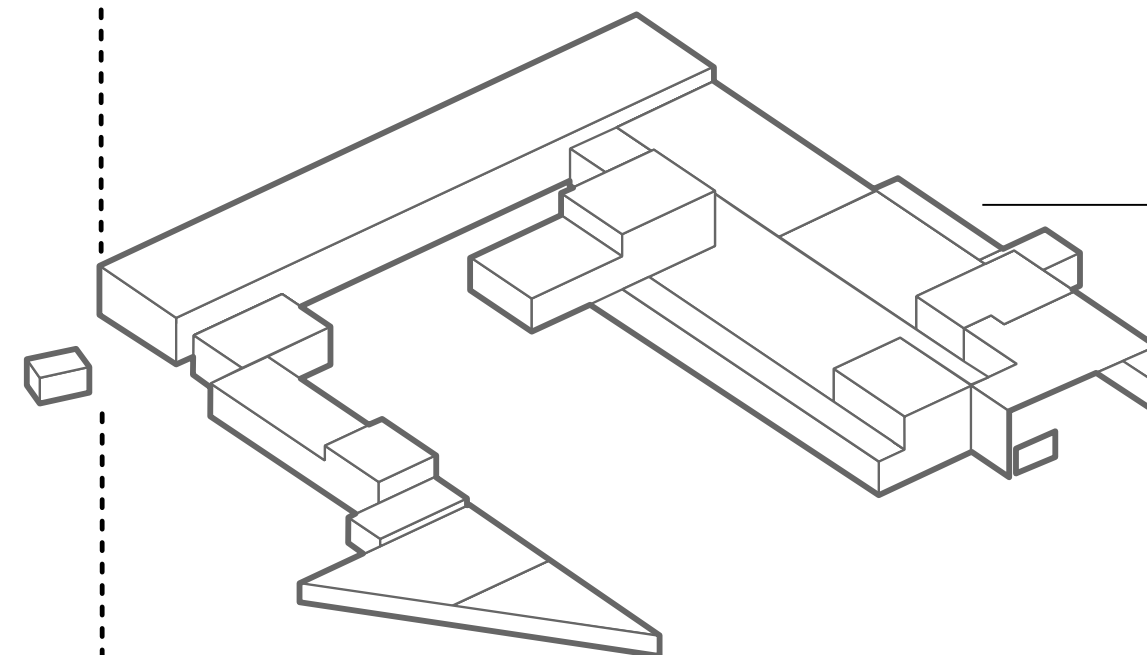

Niet behouden :  
Indifferent gewaardeerde elementen

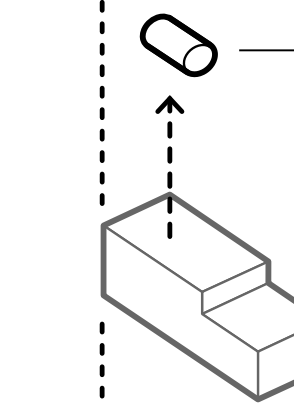

Behouden :  
De karakteristieke Backer en Rueb stoomketel uit het Ketelhuis een nieuwe plek geven

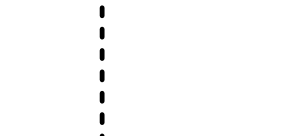

Behouden :  
Karakteristieke brandstof tank

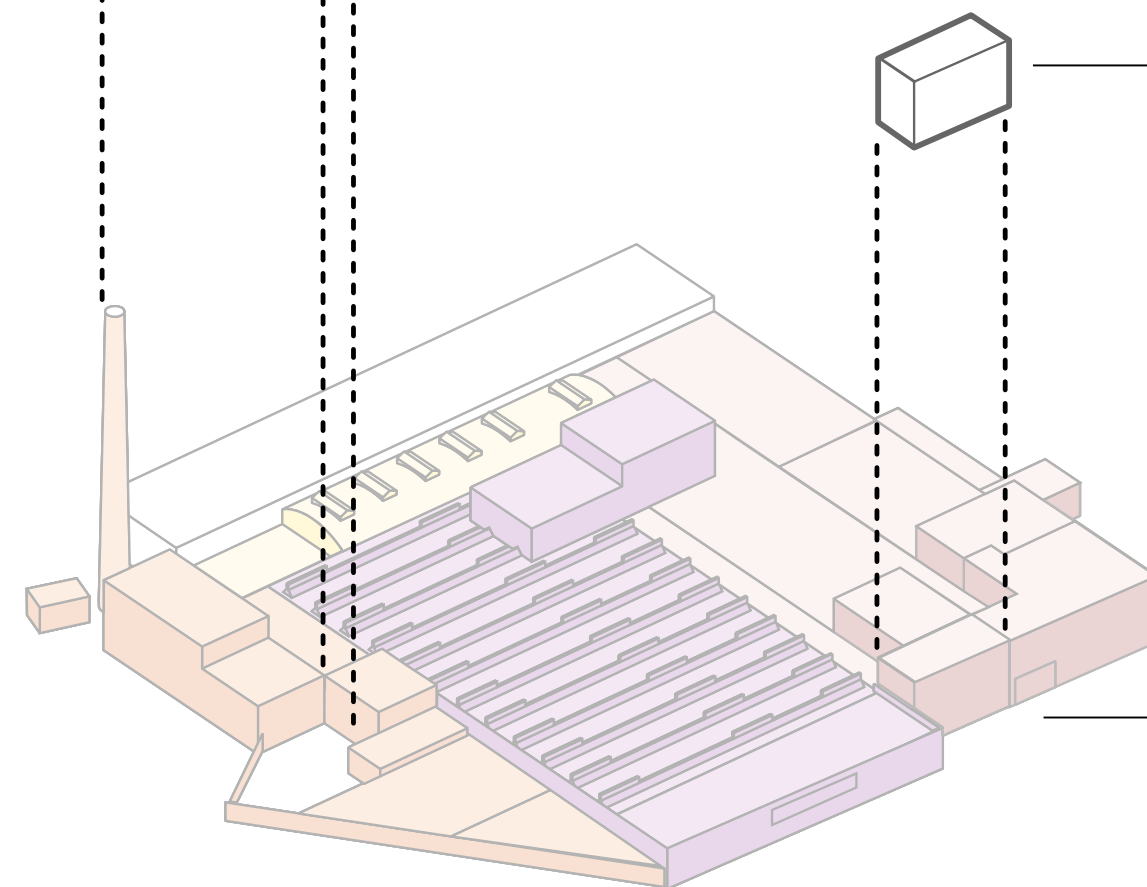

Niet behouden :  
Uitbreiding uit 1949 waarmee de open plaats werd dichtgebouwd. Wanneer de open plaats weer wordt vrijgemaakt, wordt ook de achterliggende originele kantoorstructuur uit 1912 weer zichtbaar.

Huidige situatie



# FIJN FAAM FANTASTISCH

## TOEKOMST ERFGOED

FABRIEKSHAL : WESTGEVEL



Fabriekshal westgevel, 1953

FABRIEKSHAL : INTERIEUR



Fabriekshal interieur zuidelijk deel, 2015

FUSÉEHAL : GEVELS



Fuséehal jaren, 50

KANTOOR 1912 : INTERIEUR

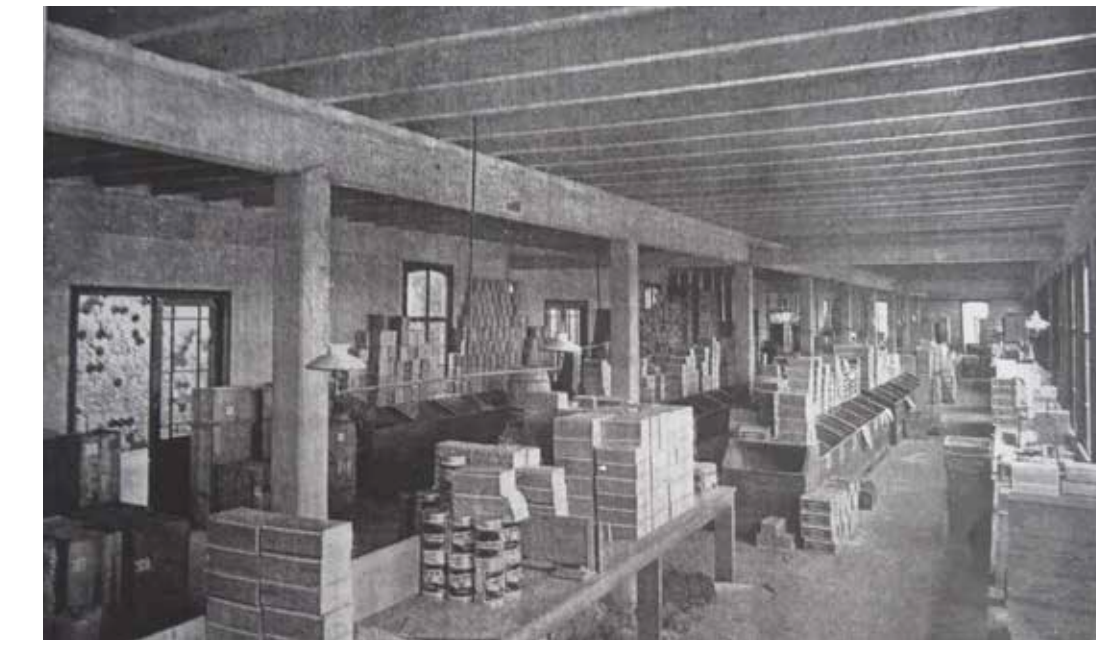

Kantoor 1912 interieur met betonstructuur, 1912

KANTOOR 1930



Kantoor 1930 exterieur, 2021



Fabriekshal westgevel en uitbreidingen, 2021



Fabriekshal interieur centraal deel, 2021



Fuséehal westgevel, 2021



Kantoor 1912 overblijfselen gevel/bestonstructuur, 2021



Ref. : onbekend

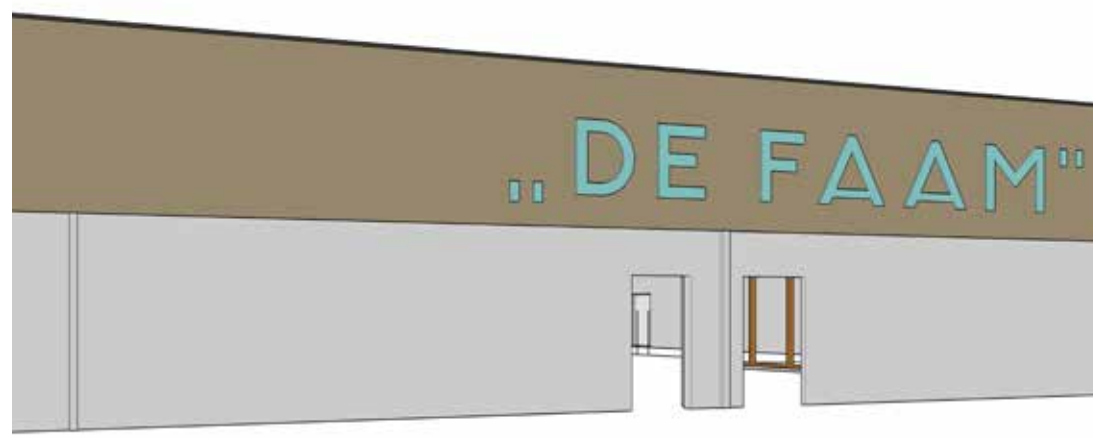

Schema : Situatie na sloop indifferente onderdelen

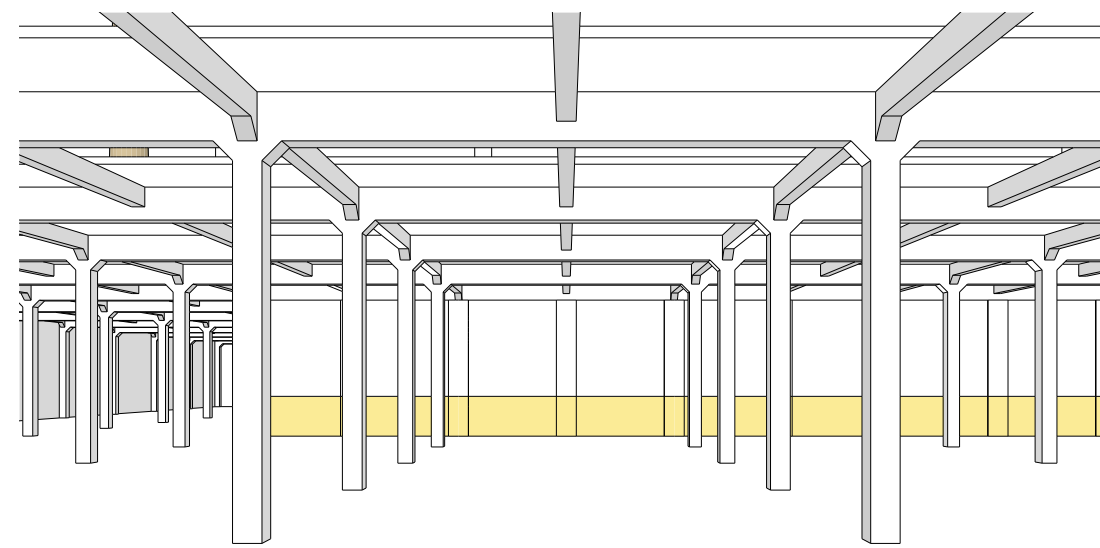

Schema : Situatie na sloop inbouwpakket tijdelijke gebruikers

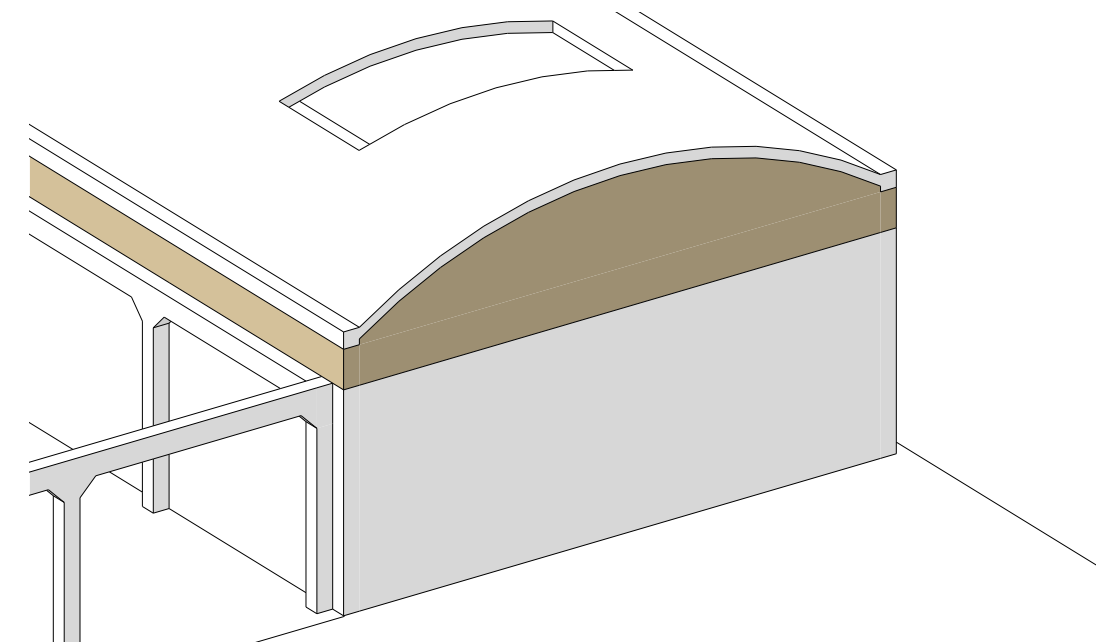

Schema : Situatie na sloop indifferente onderdelen

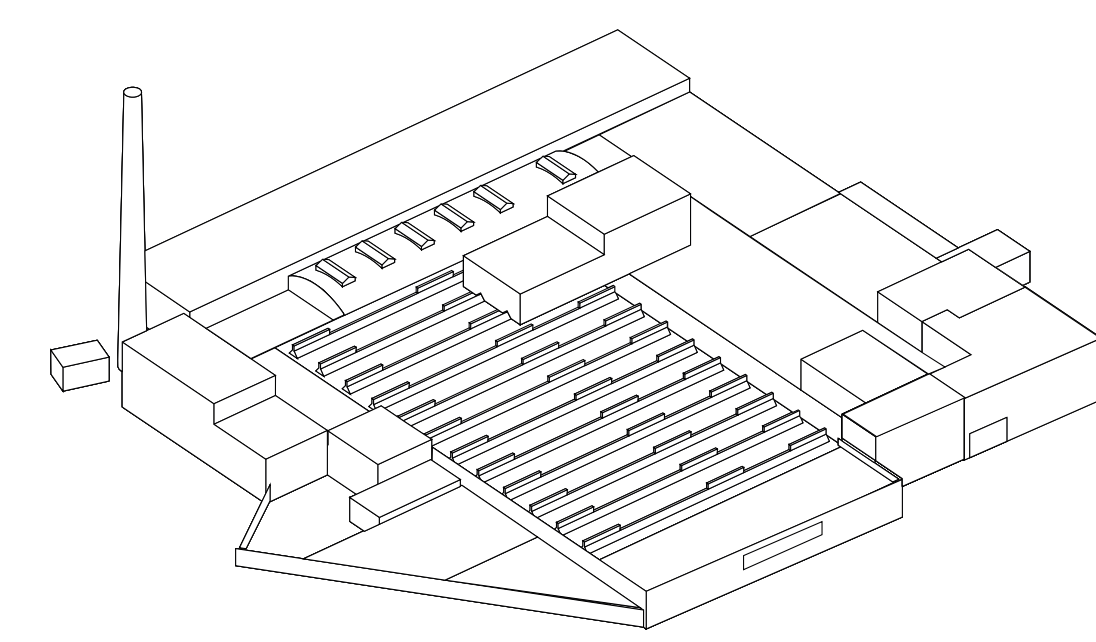

Schema : Huidige situatie

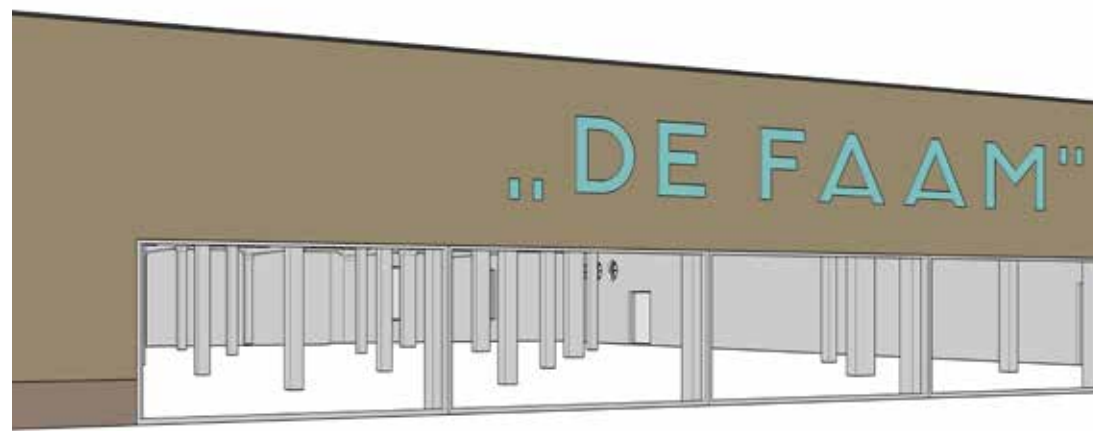

Schema : Voorstel horizontale strook met ramen

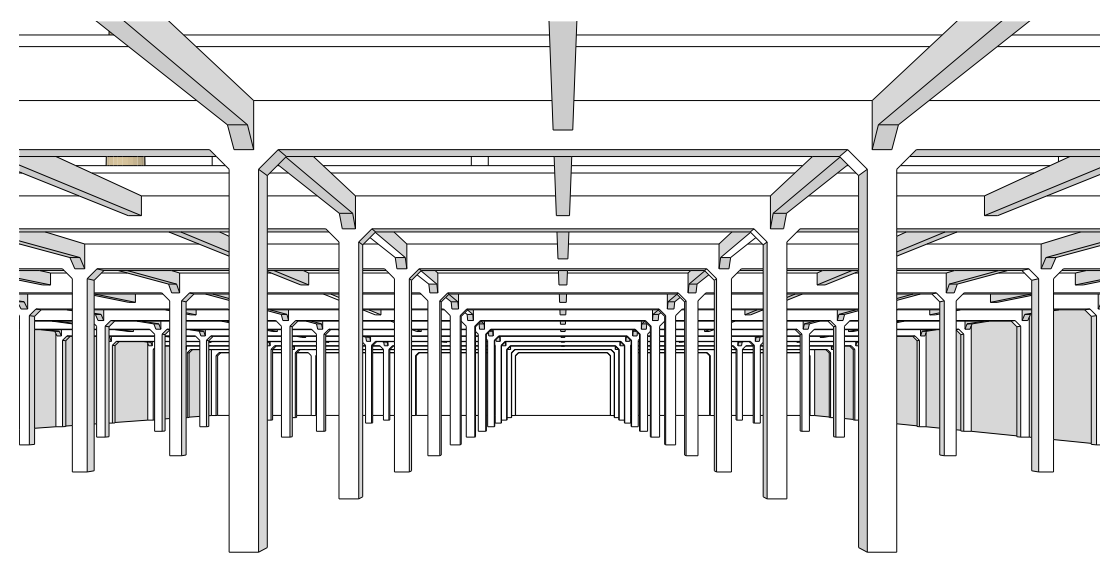

Schema : Karakteristieke structuur wordt zichtbaar

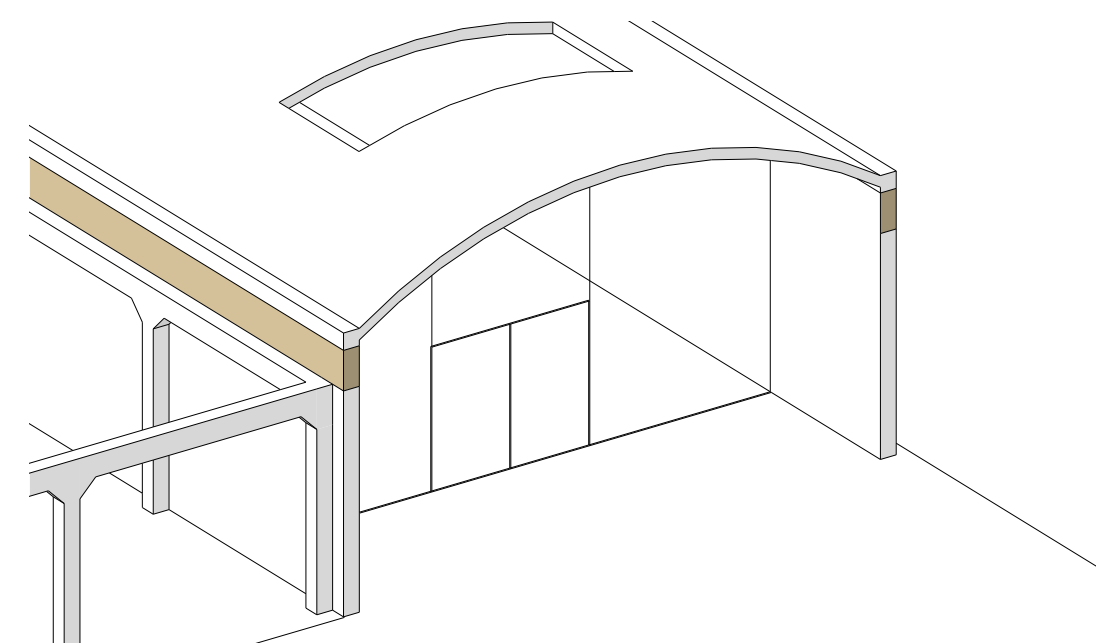

Schema : Voorstel terugliggende pui accentueert profiel van de hal

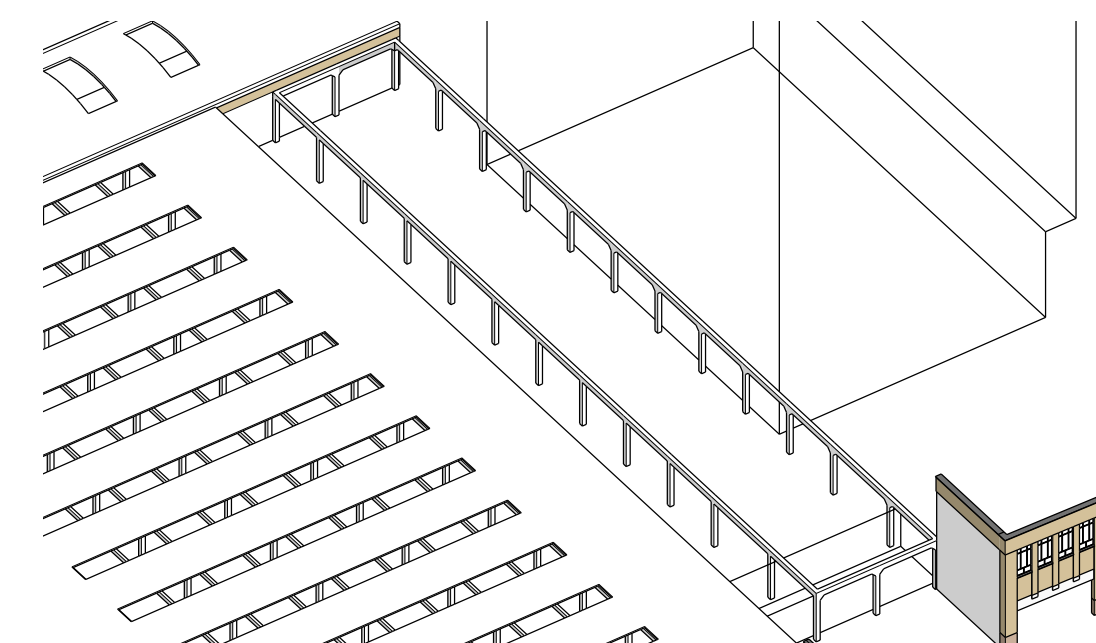

Schema : Voorstel structuur laten staan in patio



Referentie : Balenmagazijn (Gent) - TRANS architectuur stdbw.



Referentie : UCo Wagenmakerij (Utrecht) - Zecc Architecten



Referentie : Niccolò Paganini Auditorium (Parma, Italië) - RP Building



Referentie : Woonhuis (Gent, België) - Gafpa

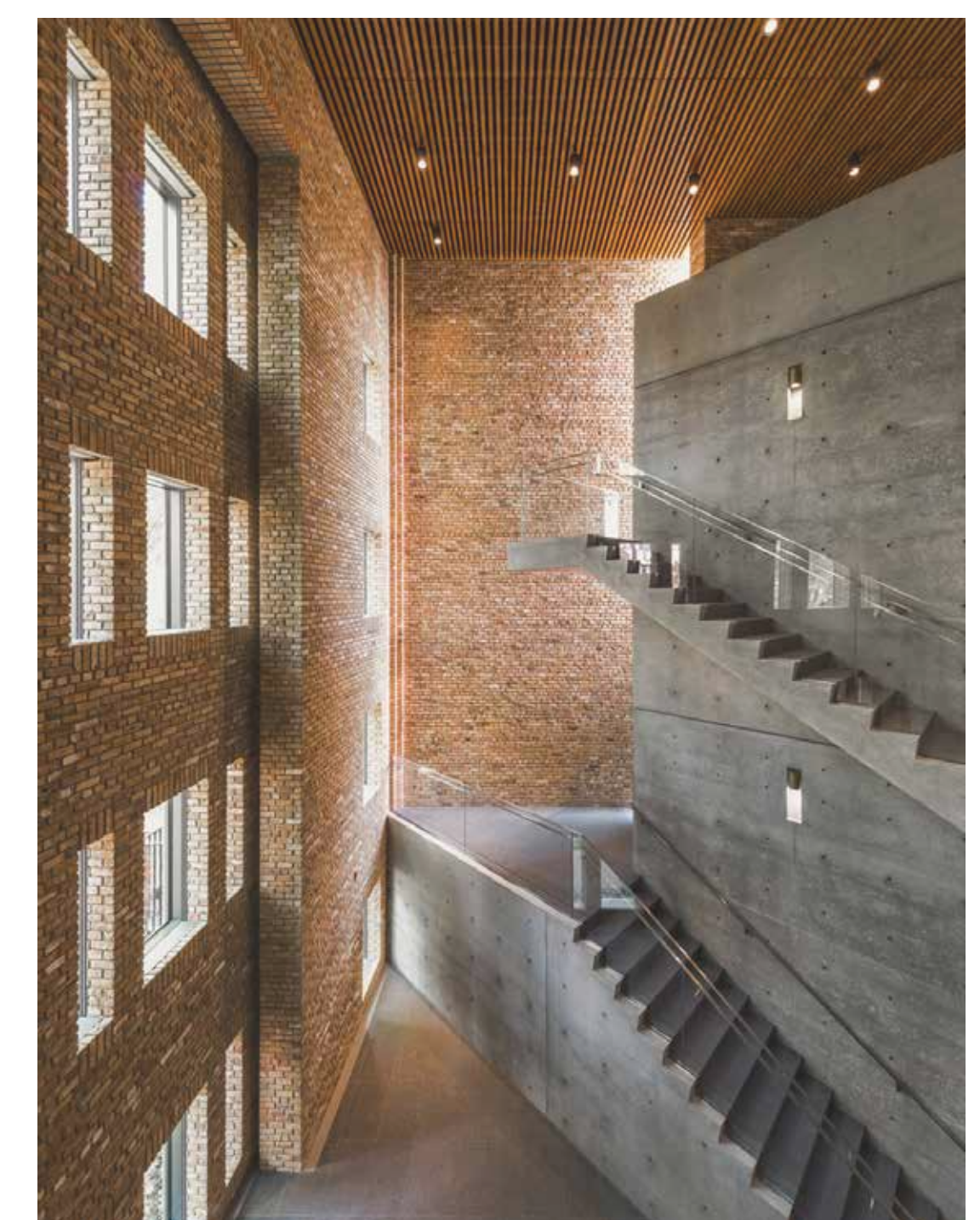

Ref : Wrightwood 659 - T. Ando



# FIJN FAAM FANTASTISCH

VISIE

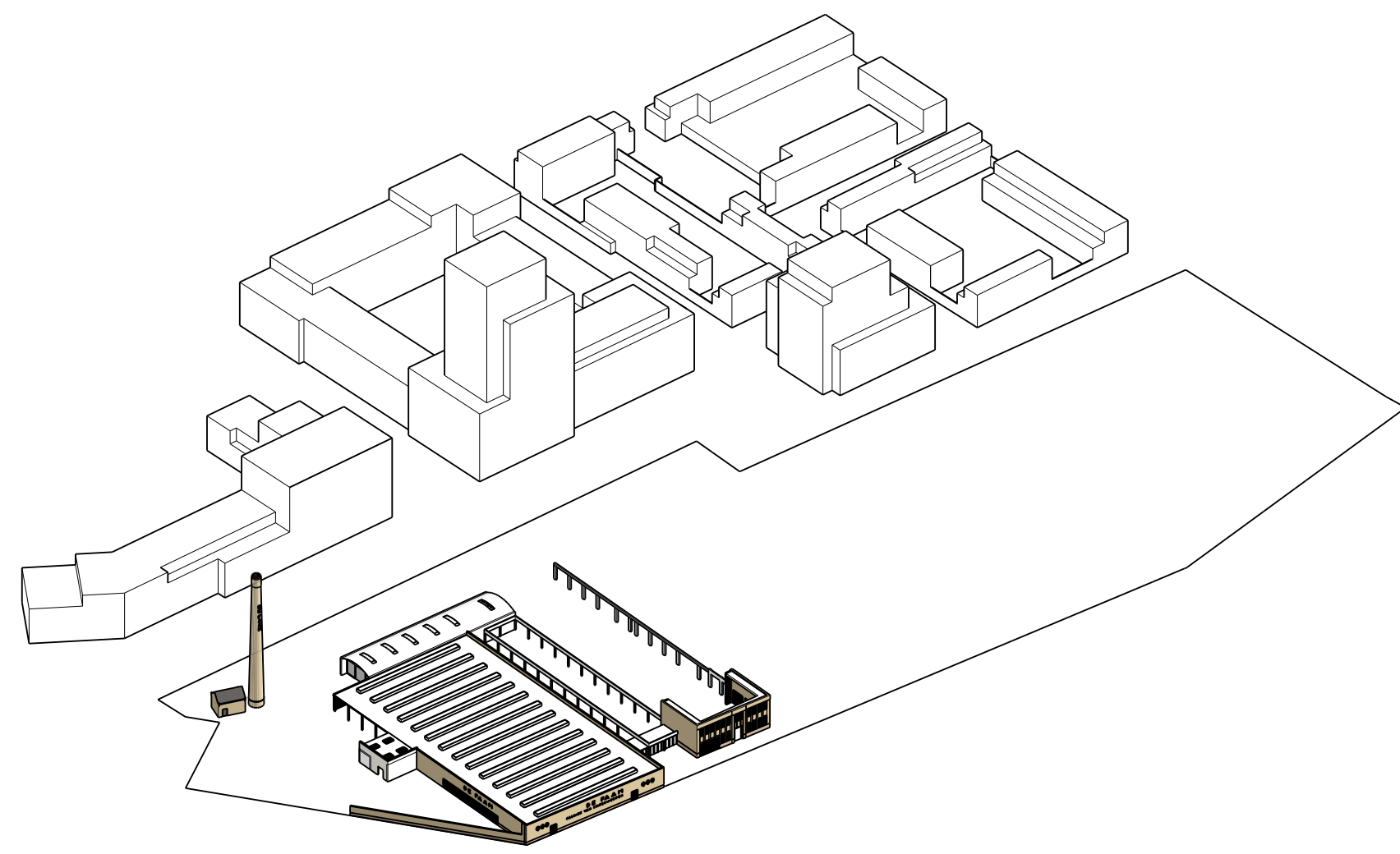

Schema Faam bestaand

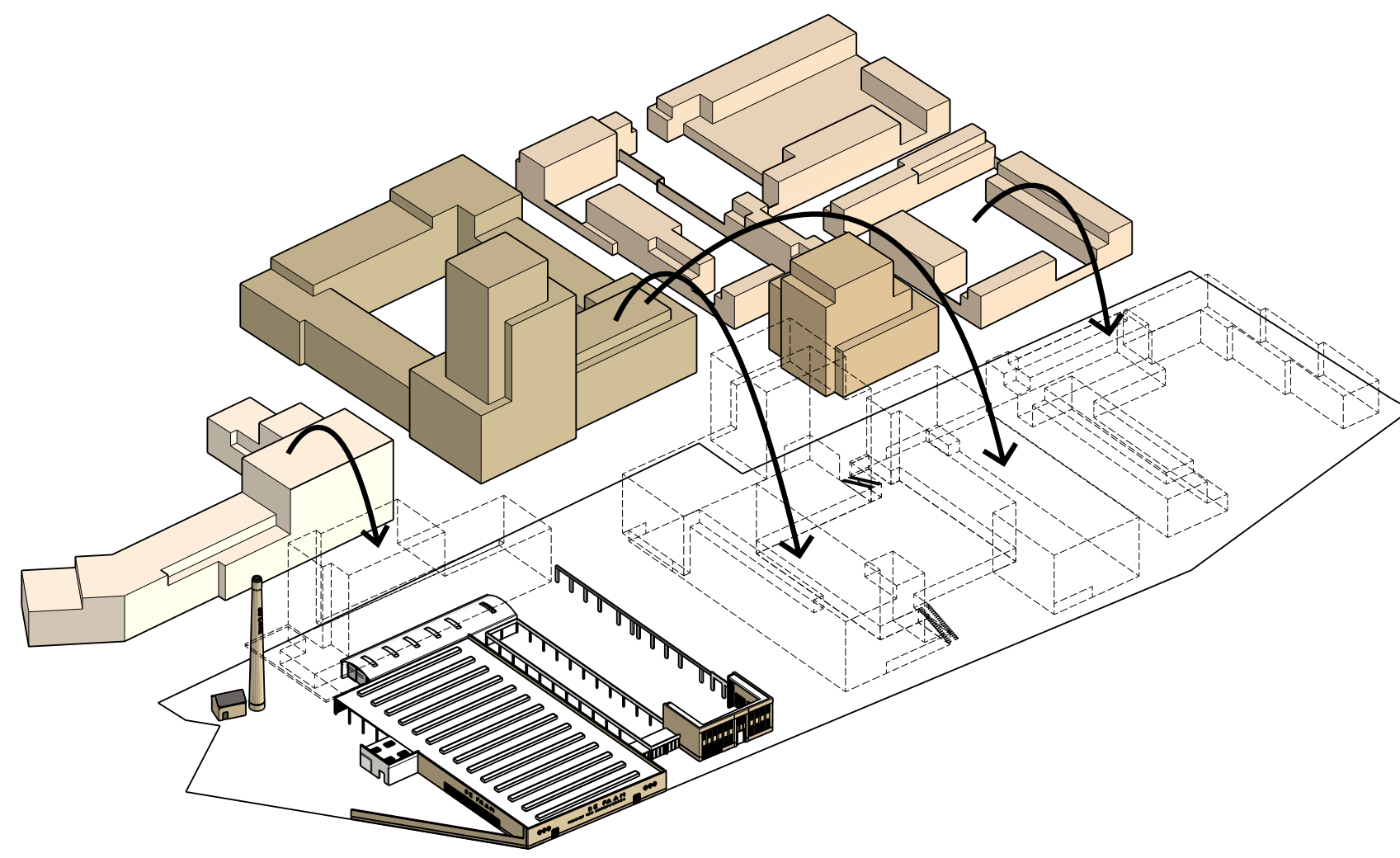

Schema : doortrekken stedelijke laag als Eureka



Referentie : Kwatta

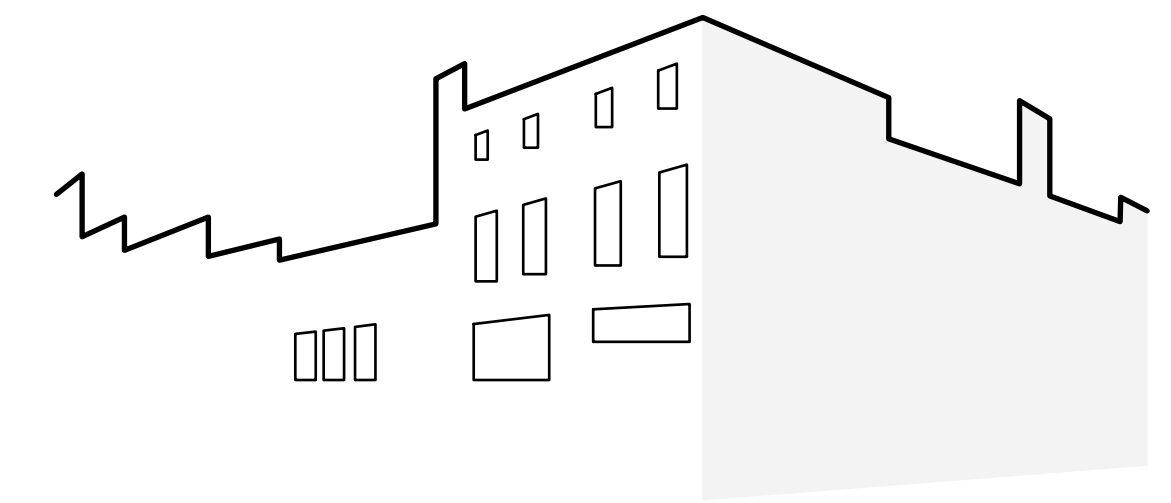

Geleding



Referentie : IJergietterij Etna

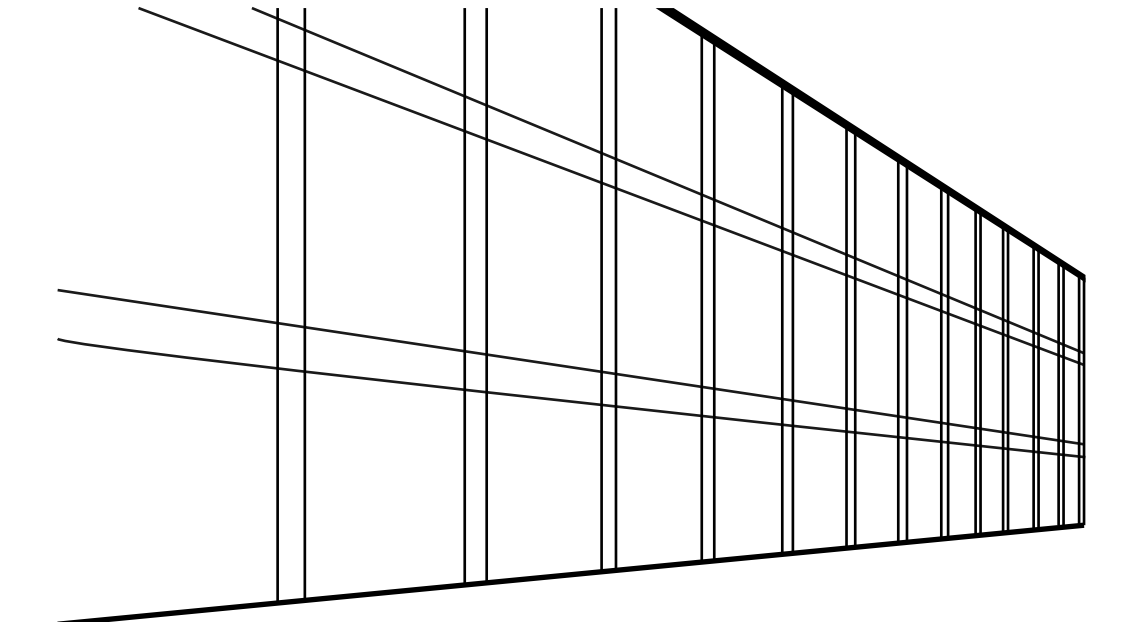

Eenduidige structuur

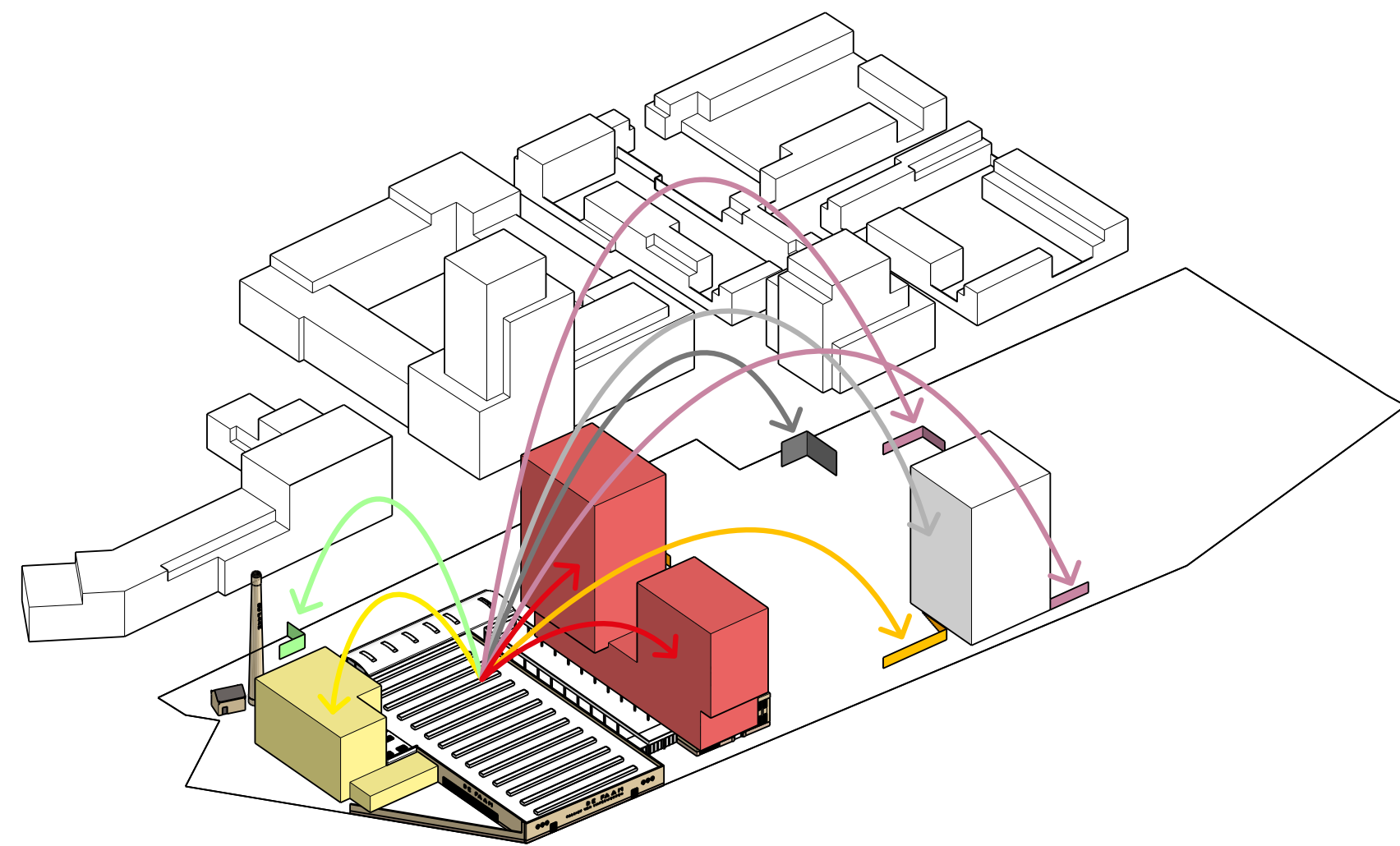

Schema : 'Faam gevoel' in de wijk versterken met nieuwe volumes

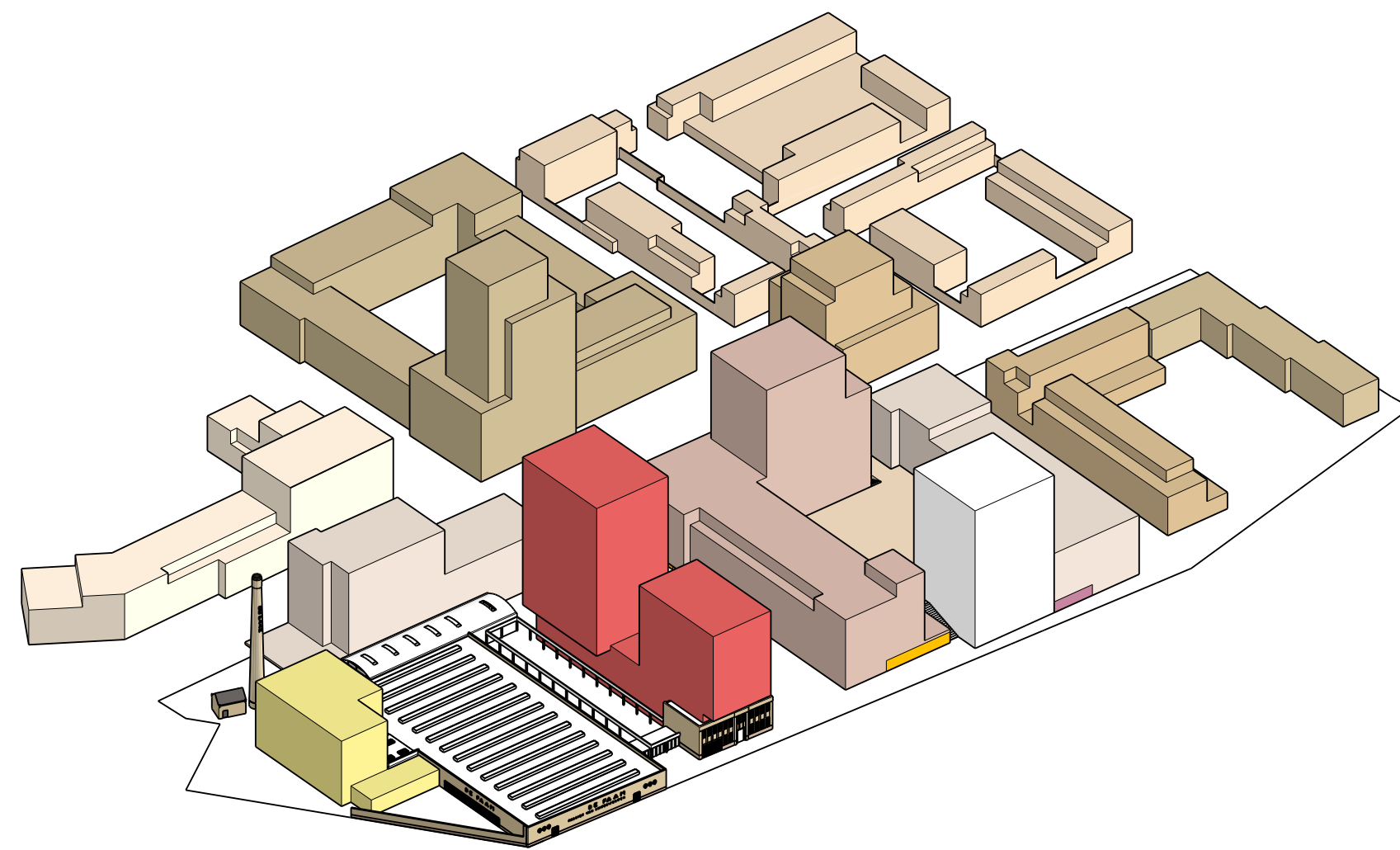

Schema : stedelijke lagen en nieuwe volumes vormen samen nieuwe ensemble



Referentie : Kwatta

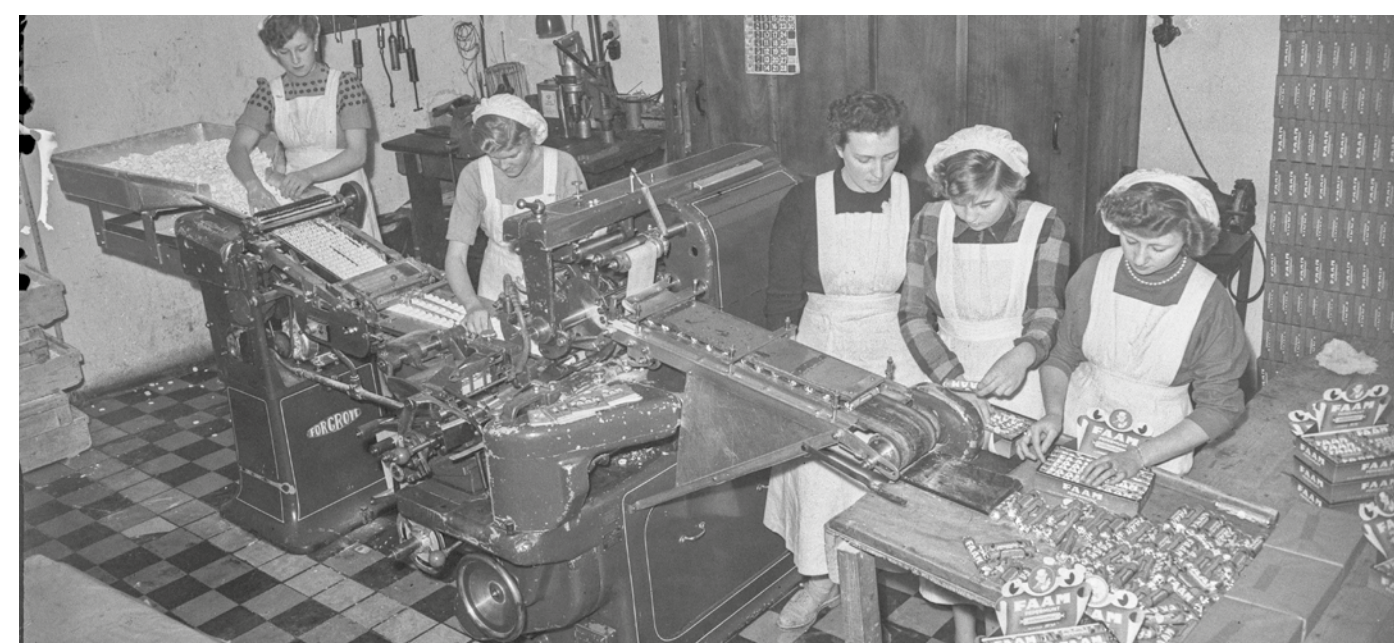

Snoepproductie in de faam rond 1955



Faam reclame posters



Faam kleuren



Zuidgevel kantoor in de jaren 40



# FIJN FAAM FANTASTISCH

## BEELDKWALITEIT

Geleding



Schets : Geleding

Ingenieursethiek



Referentie : Etna Breda

Kleuren



Snoepproductie Faam

Ornamenten

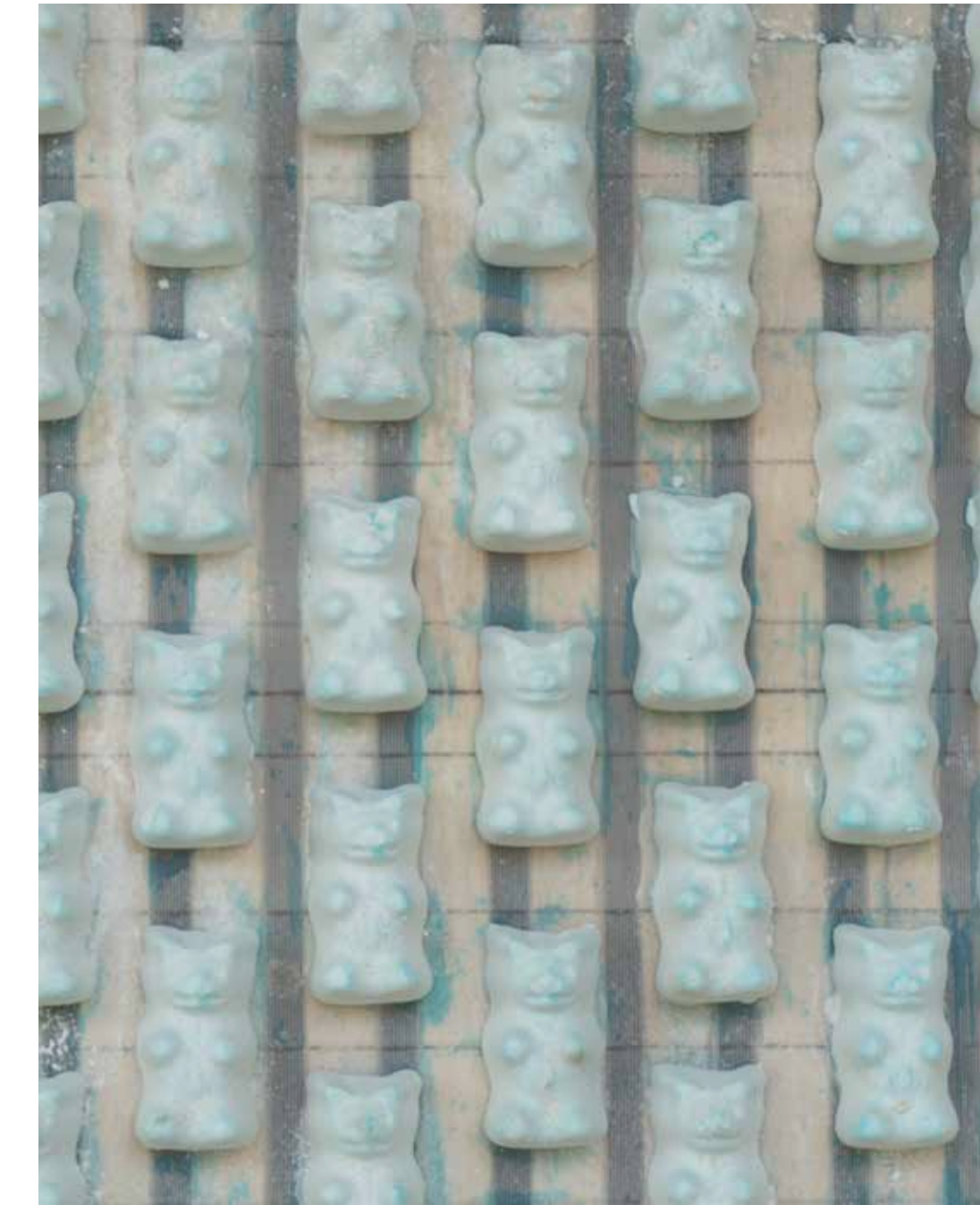

Faam contramal snoepbeertjes

Faam Typografie

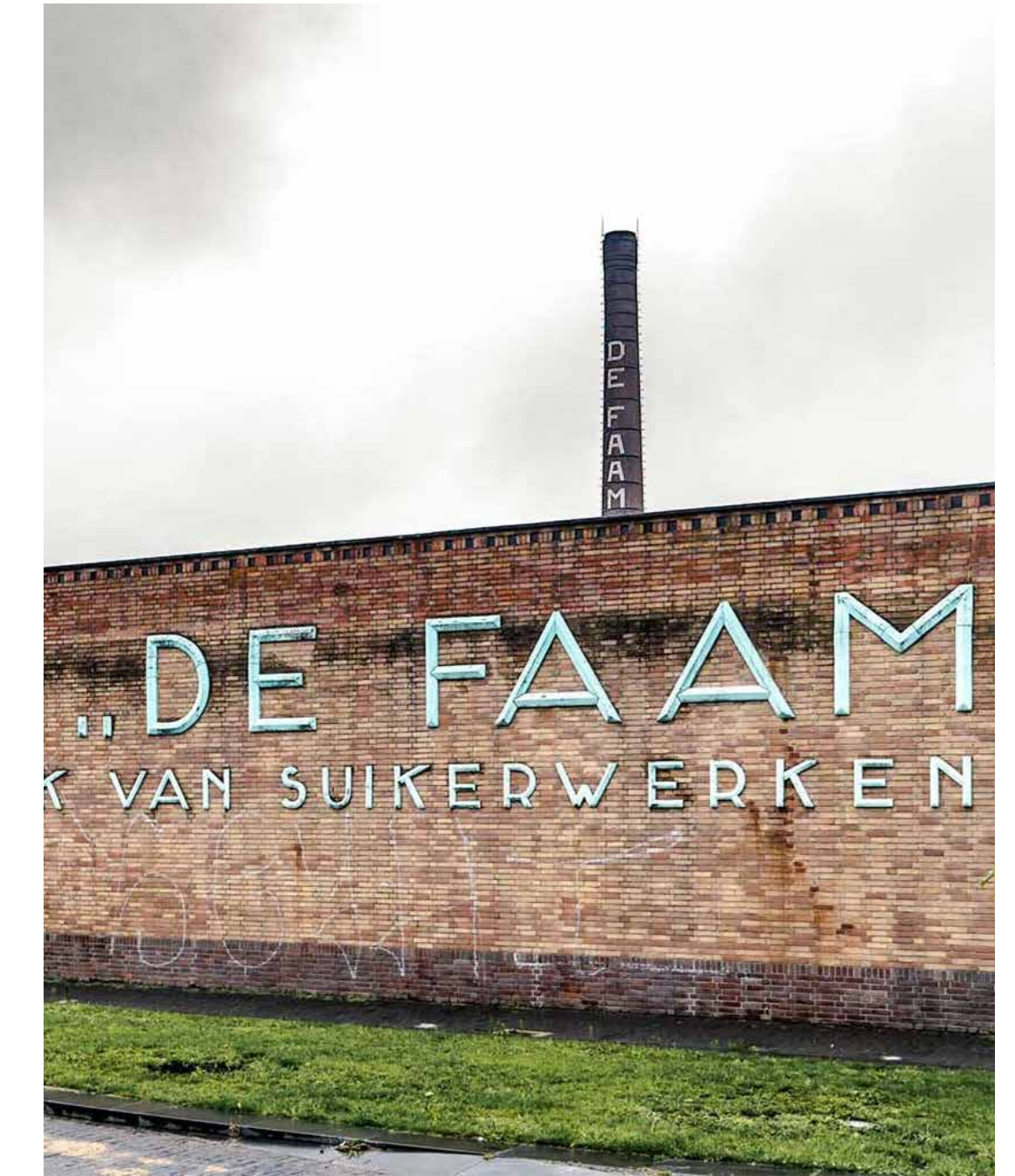

Belettering Faamgevel aan de Liniestraat

### EUREKA : SCULPTURALE METSSELWERKARCHITECTUUR

### FAAM : INGENIEURSESTHETIEK ONTMOET METSELWERKARCHITECTUUR DOOR MIDDEL VAN GELEDING



Eureka : sculpturale metselwerk architectuur

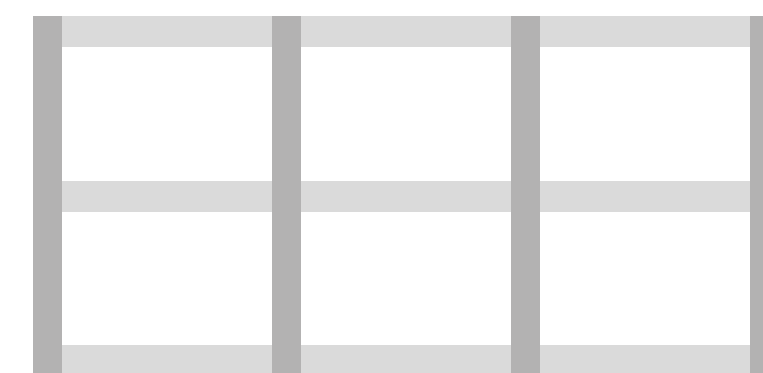

Schema : banden en penanten



Schema : horizontale gevelvlakken

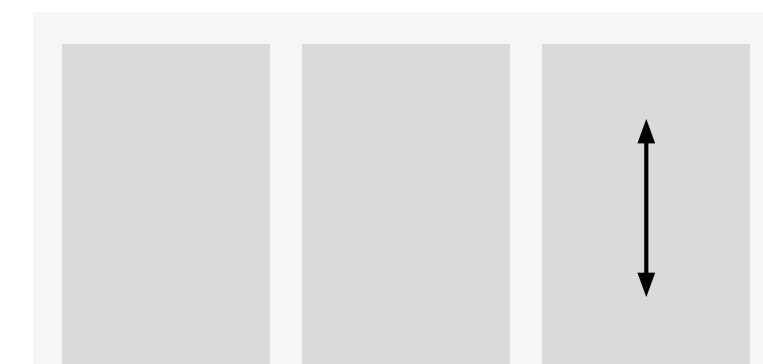

Schema : verticale gevelvlakken



Samples geglazuurde stenen

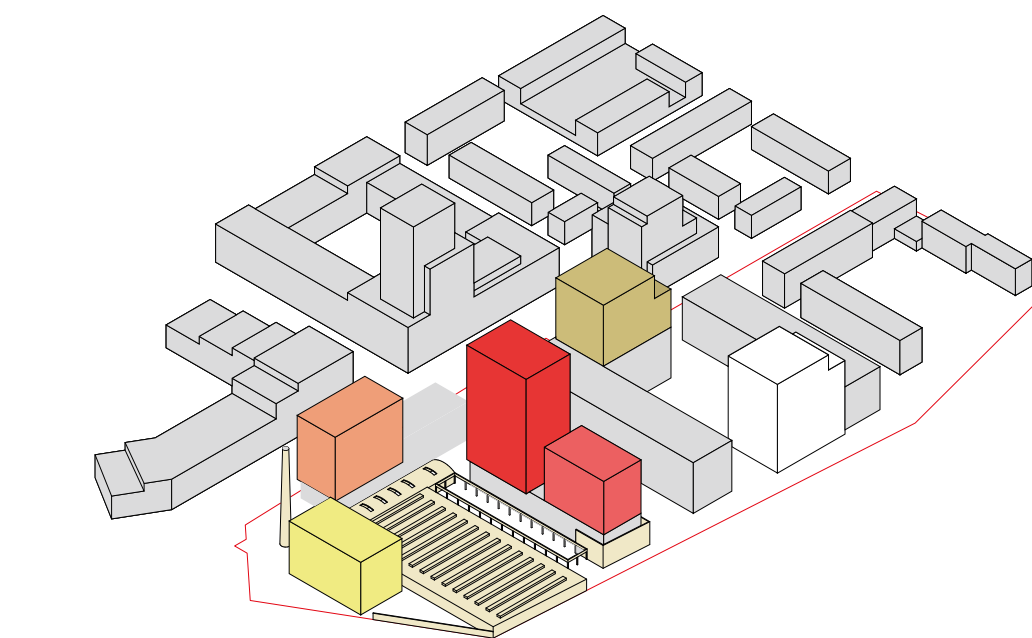

Schema : Accenten met snoepkleuren



Computermodel snoepbeertje



3D-print snoepbeertje



Geglazuurd snoepbeertjes



Bestaande letters (in blauw):

A B C D E F G H I J K L M N O P Q R S T U V W X Y Z

Afmetingen originele letters

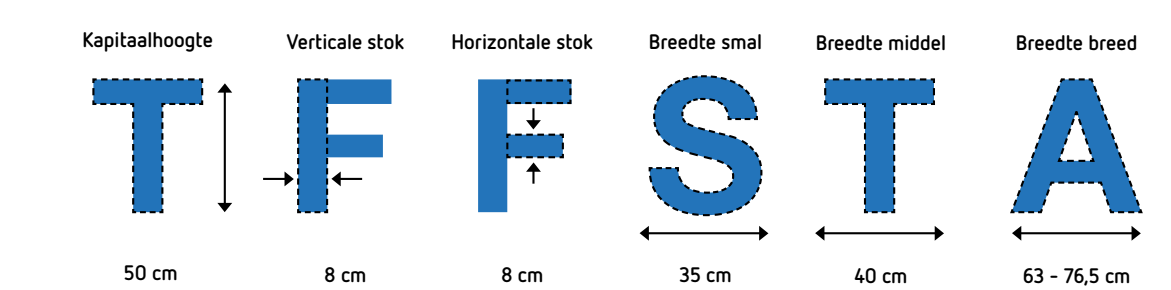

Letters breedte smal: I, J, S

Letters breedte middel: B, D, E, F, H, K, L, N, P, R, T, U, X, Y, Z

Letters breedte breed: A, M, V, W

Letters breedte rond: C, O, Q

Regel: bij ronde vormen wordt de breedte 1% groter en de lengte 2% groter

Onderzoek Faam font

ABCDEFGHIJKLM  
NOPQRSTUVWXYZ

SCHOORSTEENPLEIN  
FUSEEOPLEIN  
FUSEEHAL  
FAAMPLEIN  
APPARTEMENTEN  
FIETSENSTALLING

Voorbeeld letters en woorden in het ontworpen Faam font

## REFERENTIES INVOEGEN

Referentie : ...

Referenties : ...



Referentie : LAN Architecture - Nolistra Housing

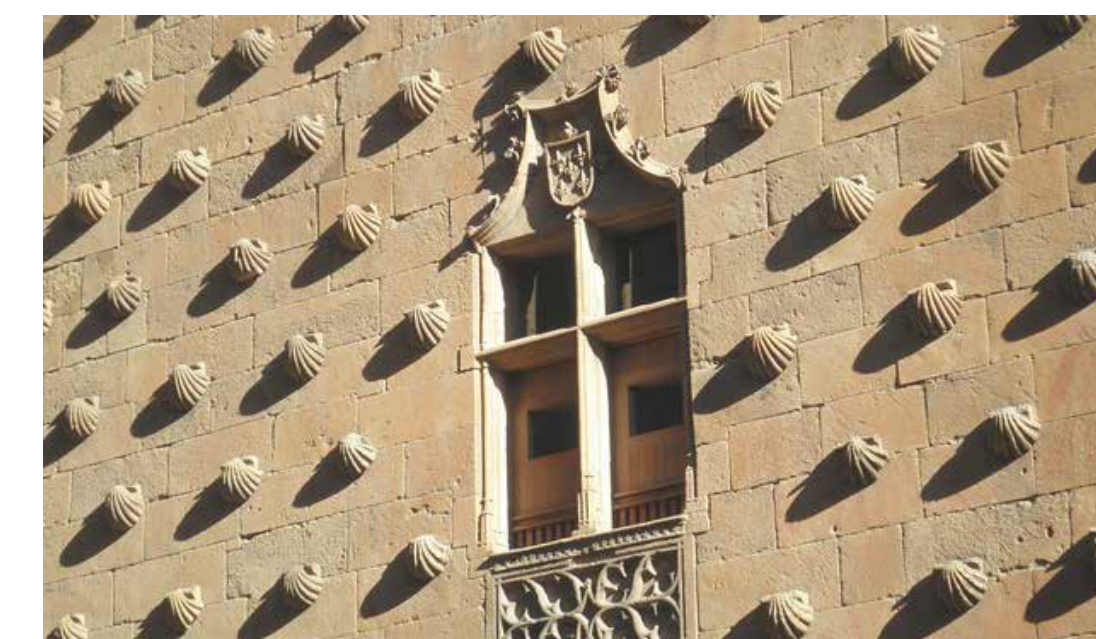

Referentie : Casa de las Conchas Salamanca



# FIJN FAAM FANTASTISCH

## LANDSCHAP

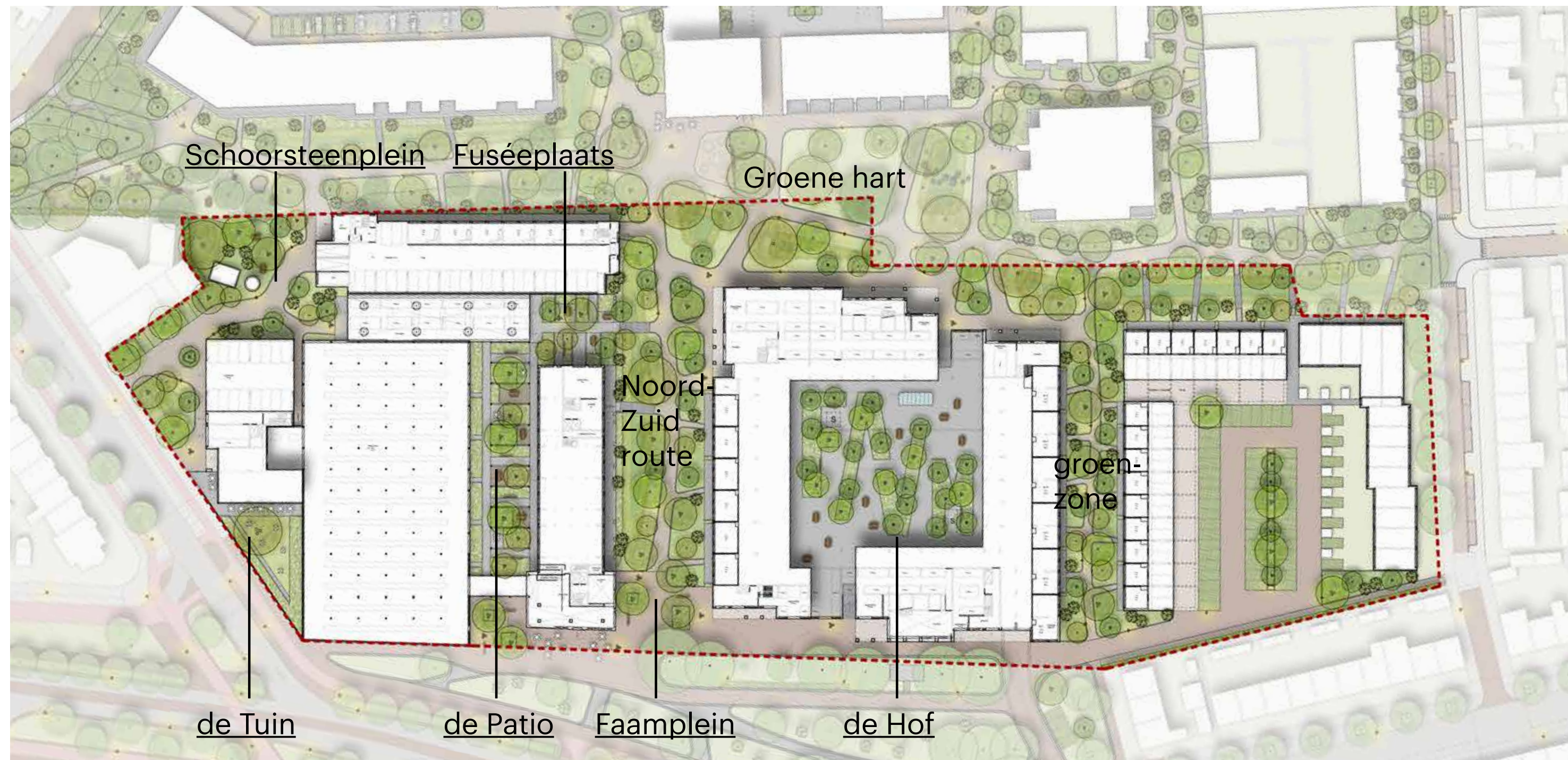

Doorlopende 'groene zone' met een serie van Faam specifieke plekken

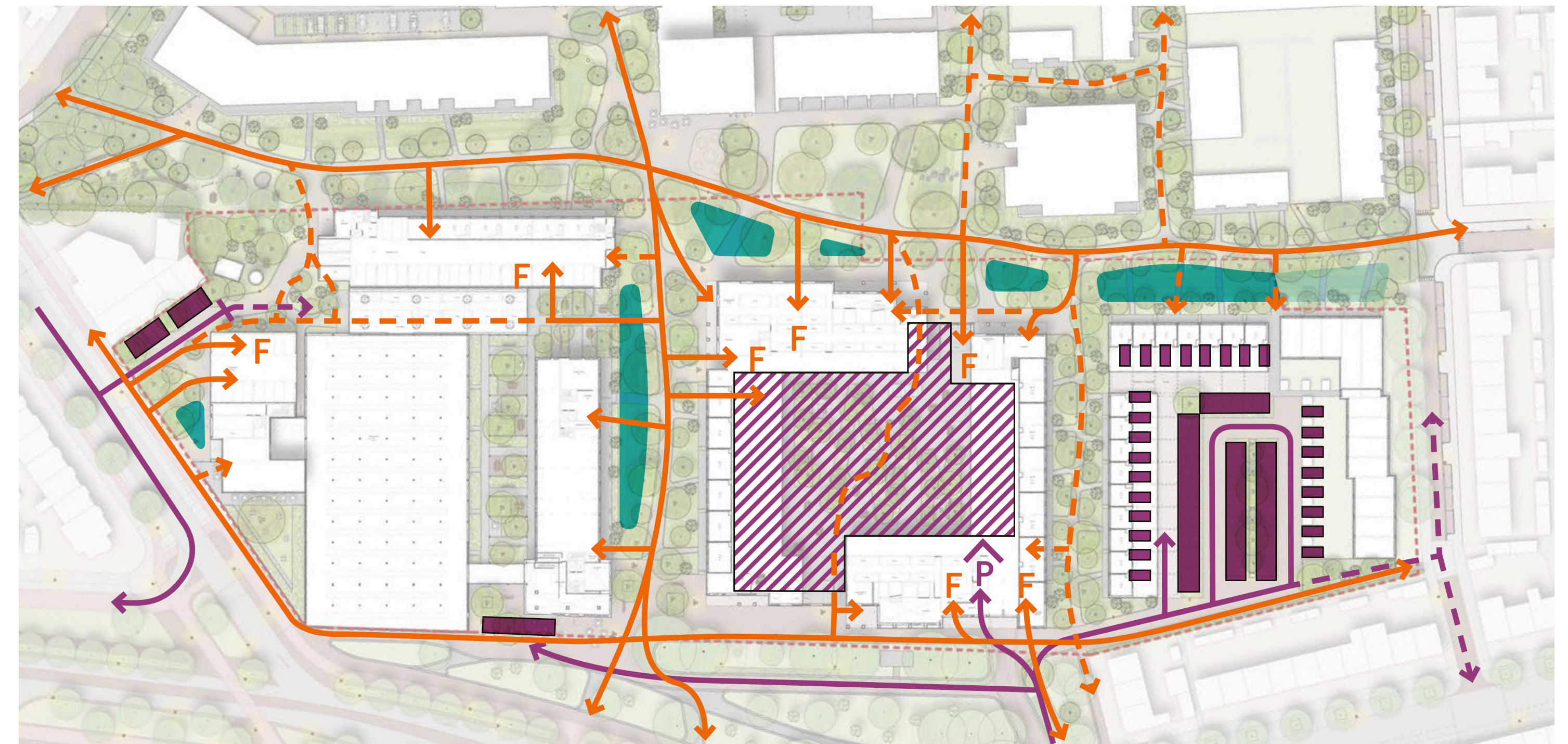

waterberging maaiveld → hoofdroute langzaam verkeer → secundaire route langzaam verkeer → parkeren → routing auto's → alternatieve route auto's (onderzoek)



Groenzone - Groene hart (visual Eureka)



Schoorsteenplein



Schoorsteenplein



de Tuin



de Tuin



Fuséeplaats



Groenzone - Noord-Zuid route



de Patio



de Patio



Faamplein



de Hof



de Hof



Referenties - Groenzone N-Z en Groenzone



Referentie - Schoorsteenplein



Referentie - de Tuin



Referentie - de Patio



Referentie - de Hof



Referenties - Faamplein



# FIJN FAAM FANTASTISCH

## NATUURINCLUSIVITEIT

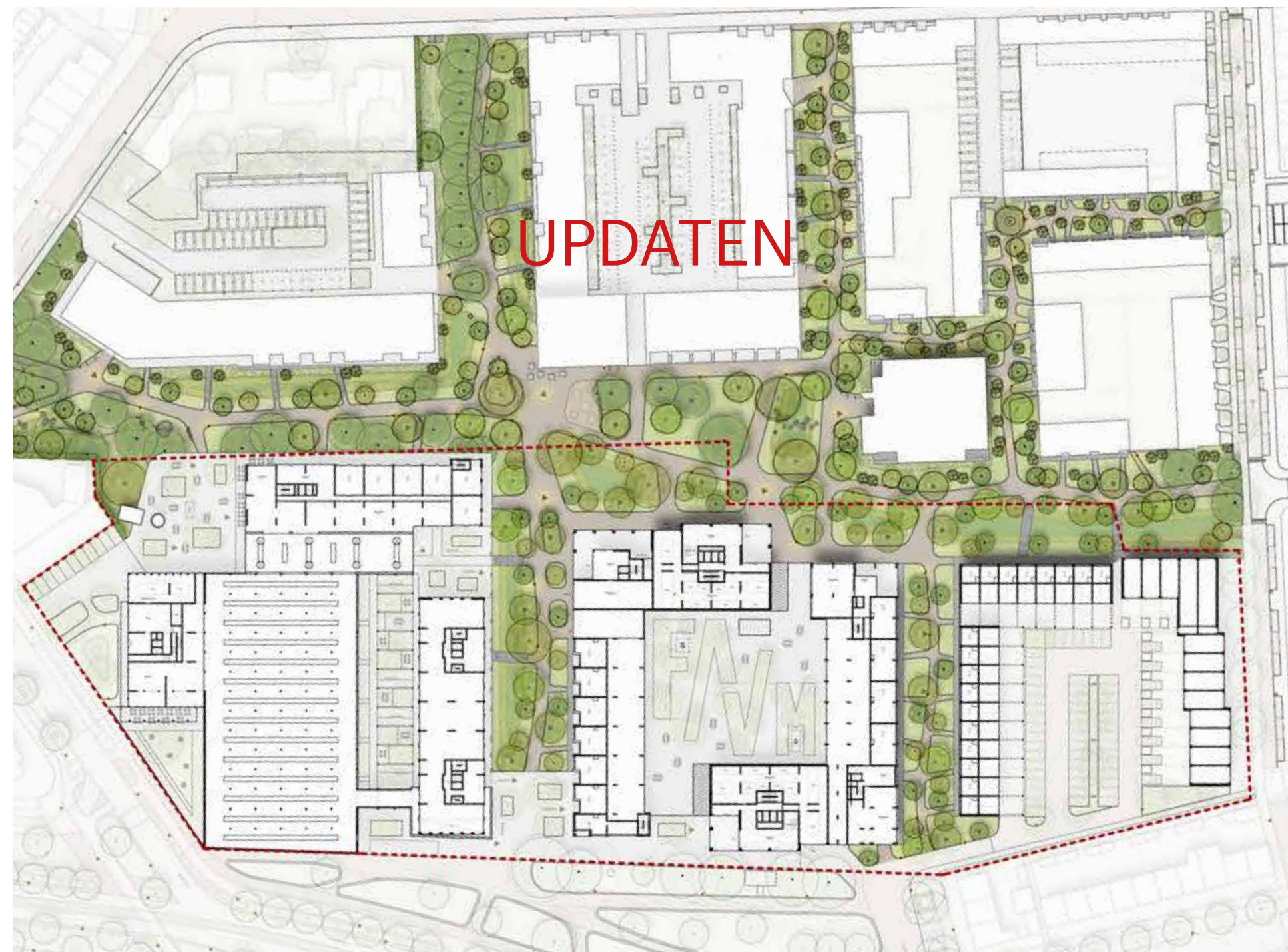

landschappelijk / extensieve stadsnatuur



stedelijke intensieve stadsnatuur

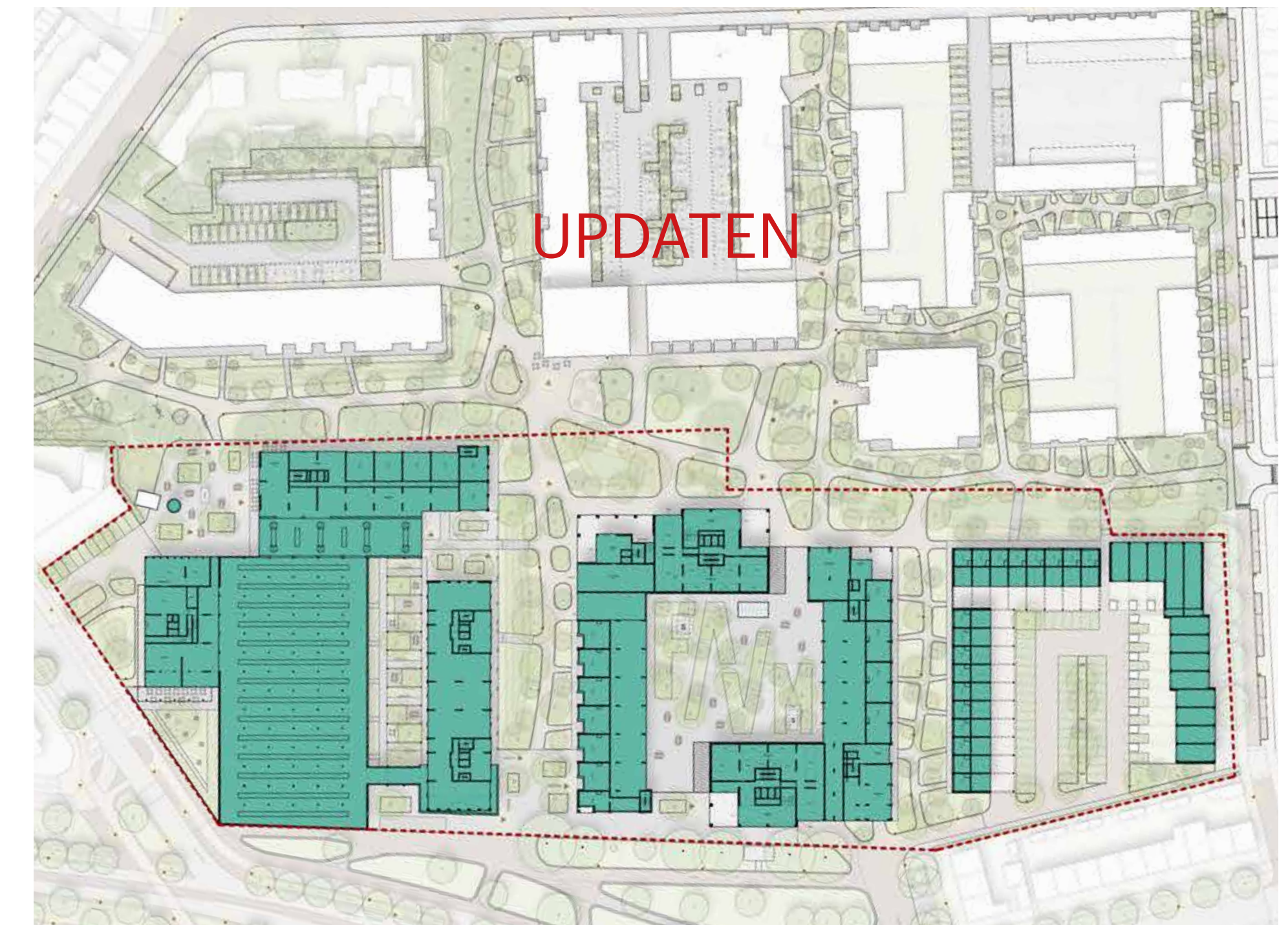

natuurinclusief bouwen



groene daken i.c.m. zonnepanelen

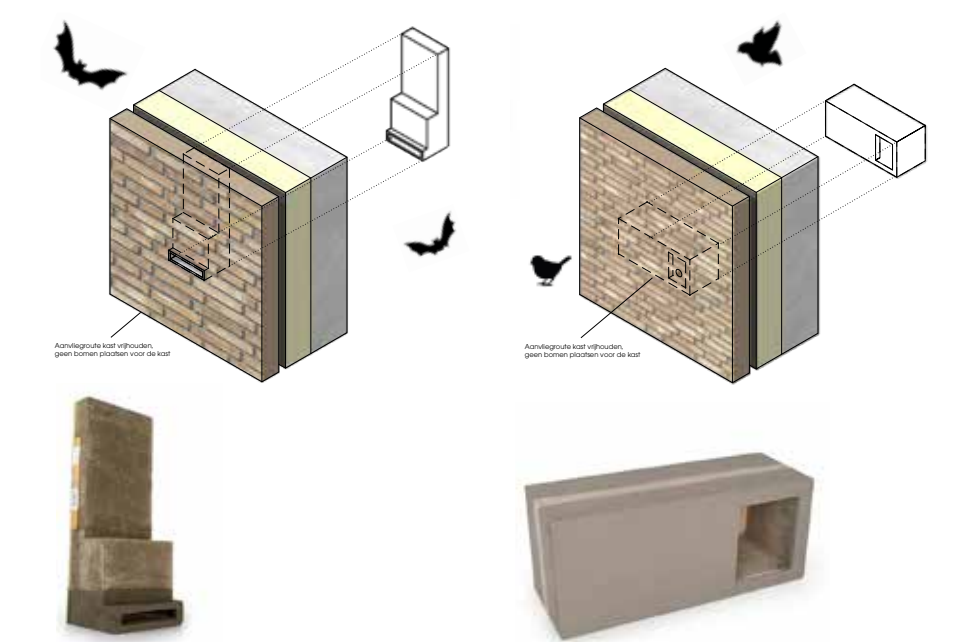

vleermuiskast integreren in gevel  
mussen-/mezen-/etc-kast integreren in gevel



groene daken



groene gevels

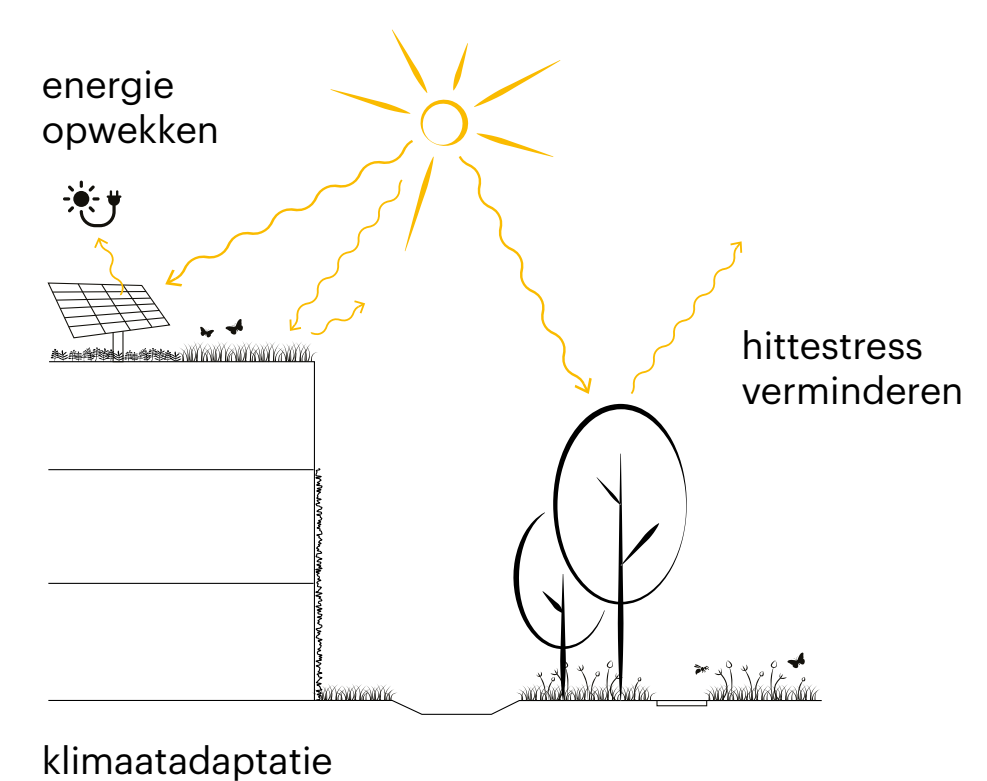
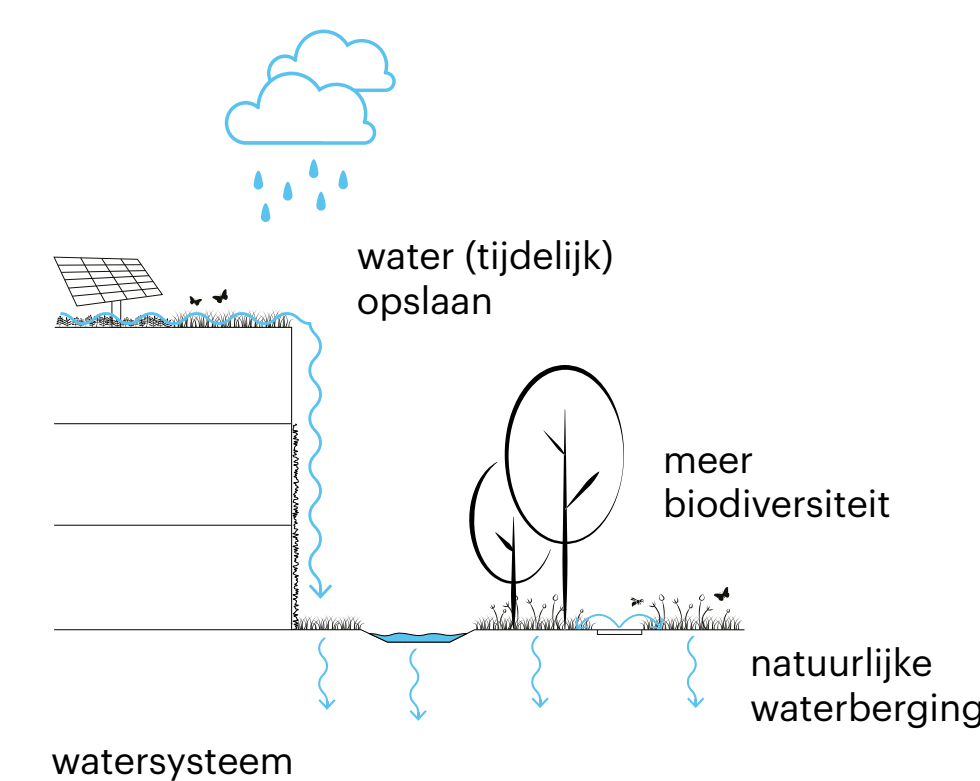



# FIJN FAAM FANTASTISCH

PLATTEGROND

